

WASH-UP BLADES LAME LAVARULLI

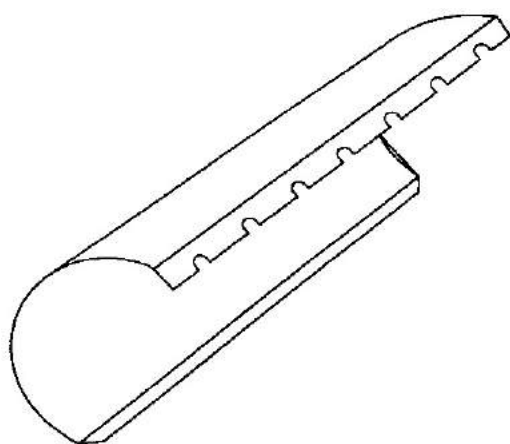
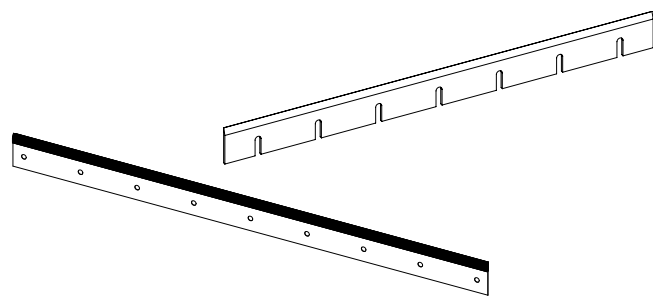

OFFSET PRINTING CYLINDER JACKETS CAMICIE DEL CILINDRO STAMPA

PUNCHING PLATES

PIASTRE PER FUSTELLARE

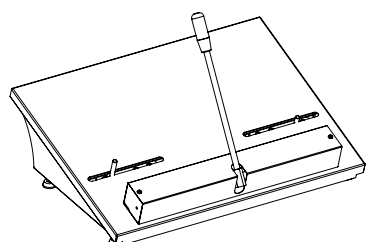
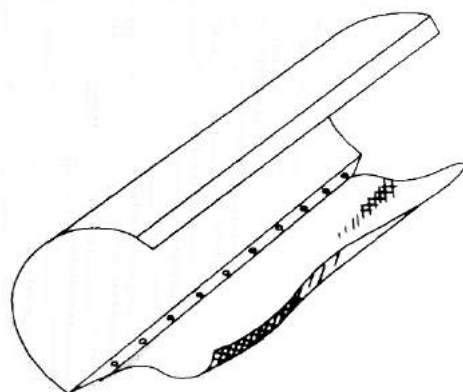

REGISTER SYSTEMS SISTEMI DI REGISTRO

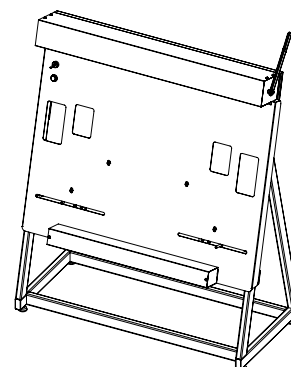

AB - DICK

Ref. Codice	Model Descrizione	Machine Size Dim. macchina	Lenght Lunghezza	Width Altezza	Thick. Spess.	Material / Materiale						€
						S+R	F+G	Gomma Rubber	Teflon	Plastic Plastica	Other Altro	
5803	AB - DICK 9995	-	360	50	5			●				
5804	AB - DICK	-	349	45	5			●				

ADAST (ROMAYOR)

Ref. Codice	Model Descrizione	Machine Size Dim. macchina	Lenght Lunghezza	Width Altezza	Thick. Spess.	Material / Materiale						€
						S+R	F+G	Gomma Rubber	Teflon	Plastic Plastica	Other Altro	
5405	GRAFOPRESS GPA/GPC/GPE	26 x 38	383	21	5			●				
5419	ADAST 500	-	547	38	0,5	●						
5410	DOMINANT 414	26 x 38	302	25	3			●				
5415	DOMINANT 313/314	35 x 50	540	28	3			●				
5420	DOMINANT 513	35 x 50	570	32	3			●				
5425	DOMINANT 514/515/524/525/526-B	35 x 50	536	24	3			●				
5426	DOMINANT 516/526/547-P	35 x 50	557	25	3			●				
5427	DOMINANT 516/526 numbering - numerazione	35 x 50	562	21	3			●				
5430	DOMINANT 712	35 x 50	630	36	3			●				
5435	DOMINANT 714/724/715/725/745/755-P	48 x 66	665	28	3			●				
5407	DOMINANT 807	-	781	38	0,5	●						
5436	DOMINANT 826	-	800	34	3			●				

AKIRA

Ref. Codice	Model Descrizione	Machine Size Dim. macchina	Lenght Lunghezza	Width Altezza	Thick. Spess.	Material / Materiale						€
						S+R	F+G	Gomma Rubber	Teflon	Plastic Plastica	Other Altro	
5972	AKIRA 18 EF	-	526	58	0,5	●						
5973	AKIRA	-	532	53	0,5	●						

AKIYAMA

Ref. Codice	Model Descrizione	Machine Size Dim. macchina	Lenght Lunghezza	Width Altezza	Thick. Spess.	Material / Materiale						€
						S+R	F+G	Gomma Rubber	Teflon	Plastic Plastica	Other Altro	
5724	AKIYAMA 26	50 x 70	790	45	5			●				
5725	AKIYAMA 28	51 x 72	810	45	5			●				
5718	AKIYAMA BESTECH 28 SPECIAL	51 x 72	805	45	5			●				
5726	AKIYAMA 40	72 x 102	1.124	50	5			●				

AURELIA (HARRIS - OMCSA)

Ref. Codice	Model Descrizione	Machine Size Dim. macchina	Lenght Lunghezza	Width Altezza	Thick. Spess.	Material / Materiale						€
						S+R L+G	Gomma Rubber	Teflon	Plastic Plastica	Other Altro		
5505	AURELIA 46/48/52/248/252	-	800	24	2				●			
5506	AURELIA 63	-	970	30	2				●			
5510	AURELIA 61/72	-	1.060	24	2				●			
5515	AURELIA 76/82/92	-	1.380	24	2				●			
5573	HARRIS 110	-	750	68	0,5	●						
5520	OMCSA A 125 up to year - fino al 1985	50 x 70	705	65	0,5	●						
5521	OMCSA A 125 over year - dopo il 1985	50 x 70	690	65	0,5	●						
5521	OMCSA A 125 numbering unit - gruppo numerazione	50 x 70	690	65	0,5	●						
5525	OMCSA A 136 HARRIS AURELIA	64 x 95	974	65	0,5	●						
5560	HARRIS 200	-	1.065	60	0,5	●						
5565	HARRIS 200	-	1.065	78	0,5	●						
5530	OMCSA A 500-520 HARRIS AURELIA	51 x 73	820	65	0,5	●						
5574	HARRIS M 600 ROTOOFFSET - WEB 16	-	1.036	53	2	●						
5535	AURELIA 700 ELITE holes - fori 100mm	70 x 100	1.070	65	0,5	●						
5534	AURELIA 700 holes - fori 95mm	70 x 100	1.070	65	0,5	●						
5555	OMCSA HARRIS 700	70 x 100	1.070	65	0,5	●						
5572	HARRIS M 850 A-B upper - superiore	-	1.065	38	0,5	●						
5565	HARRIS M 850 A-B lower - inferiore	-	1.065	78	0,5	●						
5570	HARRIS M 850 L upper - superiore	-	1.540	65	0,5	●						
5571	HARRIS M 850 L lower - inferiore	-	1.540	88	0,5	●						
5545	HARRIS 24 ROTOOFFSET 990	-	1.043	65	0,5	●						
5566	HARRIS 1.000 M200-M300	-	1.043	65	0,5	●						
5567	HARRIS 1.000	-	1.043	103	0,5	●						
5564	HARRIS M 1.000	-	1.062	103	0,5	●						

BAKER

Ref. Codice	Model Descrizione	Machine Size Dim. macchina	Lenght Lunghezza	Width Altezza	Thick. Spess.	Material / Materiale						€
						S+R L+G	Gomma Rubber	Teflon	Plastic Plastica	Other Altro		
5727	BAKER 2 PERKINS 126 upper - superiore	-	1.023	73	0,5	●						
5728	BAKER 2 PERKINS 126 lower - inferiore	-	1023	65	0,5	●						
5732	BAKER PERKINS WEB G16	-	975	65	0,5	●						

CANVIT

Ref. Codice	Model Descrizione	Machine Size Dim. macchina	Lenght Lunghezza	Width Altezza	Thick. Spess.	Material / Materiale						€
						S+R F+G	Gomma Rubber	Teflon	Plastic Plastica	Other Altro		
5937	CANVIT FLEXI ROLLS	-	514	35	3				●			
5938	CANVIT FLEXI ROLLS	-	530	42	3				●			

CODIMAG

Ref. Codice	Model Descrizione	Machine Size Dim. macchina	Lenght Lunghezza	Width Altezza	Thick. Spess.	Material / Materiale						€
						S+R F+G	Gomma Rubber	Teflon	Plastic Plastica	Other Altro		
5935	CODIMAX MIXTE - HAMADA 80	-	540	40	5		●					
5936	CODIMAG M13 - M16 - M21	-	535	37	5		●					

CRABTREE

Ref. Codice	Model Descrizione	Machine Size Dim. macchina	Lenght Lunghezza	Width Altezza	Thick. Spess.	Material / Materiale						€
						S+R F+G	Gomma Rubber	Teflon	Plastic Plastica	Other Altro		
5689	CRABTREE 40 tin lithographic press	-	1.100	152	7				●			
5691	CRABTREE 45 tin lithographic press	-	1.220	152	7				●			
5695	CRABTREE 1.200 tin lithographic press - 130	-	1.345	43	0,5	●						
5692	CRABTREE	-	1.100	150	6				●			

DAVIDSON

Ref. Codice	Model Descrizione	Machine Size Dim. macchina	Lenght Lunghezza	Width Altezza	Thick. Spess.	Material / Materiale						€
						S+R F+G	Gomma Rubber	Teflon	Plastic Plastica	Other Altro		
5760	DAVIDSON 500/501/502p	25 x 35	298	60	0,5	●						
5765	DAVIDSON 700/701/702p	45 x 38	470	60	0,5	●						
5770	DAVIDSON 900/901/902p	35 x 50	530	60	0,5	●						

DIDDE

Ref. Codice	Model Descrizione	Machine Size Dim. macchina	Lenght Lunghezza	Width Altezza	Thick. Spess.	Material / Materiale						€
						S+R F+G	Gomma Rubber	Teflon	Plastic Plastica	Other Altro		
5947	DIDDE GLASER APOLLO 8 ^{1/4} " - 8 ^{1/2} "	-	405	35	3				●			
5949	DIDDE GLASER 860	-	495	35	1,5				●			
5952	DIDDE GLASER VIP	-	571	35	1,5				●			
5950	DIDDE CONSERVER PRESS	-	396	58	0,5	●						

DRENT

Ref. Codice	Model Descrizione	Machine Size Dim. macchina	Lenght Lunghezza	Width Altezza	Thick. Spess.	Material / Materiale						€
						S+R F+G	Gomma Rubber	Teflon	Plastic Plastica	Other	Altro	
5953	DRENT GAZELLE 8	-	480	45	2				●			
5954	DRENT GAZELLE 2 B	-	575	31	5			●				
5955	DRENT GAZELLE 3 C	-	555	30	5			●				
5957	DRENT GAZELLE 4 D	-	585	23	2				●			
5956	DRENT GAZELLE 4 F	-	600	30	2				●			
5958	DRENT GAZELLE 5 E	-	575	50	2				●			
5956	DRENT GAZELLE 4 G	-	600	30	2				●			
5959	DRENT GAZELLE 6 K	-	508	35	3				●			
5985	DRENT GAZELLE 6 L	-	520	40	3				●			
5960	DRENT GAZELLE 6 P	-	540	40	3				●			
5989	DRENT GAZELLE 6 T	-	535	35	2				●			
5904	DRENT GAZELLE 6 IMR	-	560	36	3				●			
5961	DRENT GAZELLE L	-	564	35	2				●			
5990	DRENT GAZELLE VISION	-	575	33	3				●			
5740	DRENT GAZELLE VISION	-	570	30	0,5	●						

EDELMAN FORM-ALL

Ref. Codice	Model Descrizione	Machine Size Dim. macchina	Lenght Lunghezza	Width Altezza	Thick. Spess.	Material / Materiale						€
						S+R F+G	Gomma Rubber	Teflon	Plastic Plastica	Other	Altro	
5924	VARIO PRINT	-	576	60	0,5	●						
5924	WEB PRINT 52	-	576	60	0,5	●						
5911	FORM PRINT	-	490	65	0,5	●						
5923	PACK PRINT ROLL P.P.	-	415	58	0,5	●						
5923	COMPUTER PRINT V38 - C38	-	415	58	0,5	●						
5375	MINI PRINT	-	550	58	0,5	●						
5912	EDELMAN WEB 39	-	410	60	0,5	●						
5901	EDELMAN WEB 48,5	-	520	60	0,5	●						
5914	EDELMAN WEB V 72	-	774	58	0,5	●						

FAG

Ref. Codice	Model Descrizione	Machine Size Dim. macchina	Lenght Lunghezza	Width Altezza	Thick. Spess.	Material / Materiale						€
						S+R F+G	Gomma Rubber	Teflon	Plastic Plastica	Other	Altro	
5996	WIFAG 07 ROTOOFFSET	-	820	33	0,5	●						
5997	FAG OP 104 - 104 ALFA - 104 BETA	-	1.090	58	0,5	●						
5998	FAG 4 COLORS	70 x 100	1.158	48	0,5	●						
6025	WIFAG 160	-	1.610	48	0,5	●						

FORM CONSULTA

Ref. Codice	Model Descrizione	Machine Size Dim. macchina	Lenght Lunghezza	Width Altezza	Thick. Spess.	Material / Materiale						€
						S+R F+G	Gomma Rubber	Teflon	Plastic Plastica	Other	Altro	
5925	FORM CONSULTA FC 50	-	550	26	0,5	●						
5926	FORM CONSULTA FC 50 old model	-	570	26	0,5	●						
5927	FORM CONSULTA FC 50 numbering - numeraz.	-	590	26	0,5	●						

FUJI - SHINOHARA

Ref. Codice	Model Descrizione	Machine Size Dim. macchina	Lenght Lunghezza	Width Altezza	Thick. Spess.	Material / Materiale						€
						S+R F+G	Gomma Rubber	Teflon	Plastic Plastica	Other	Altro	
5605	FUJI 50	35 x 50	550	48	2	●						
5610	FUJI 52	36 x 52	580	43	2	●						
5611	FUJI 52 numbering unit - gruppo numerazione	36 x 52	500	26	0,2						●	
5615	FUJI 58	-	620	53	2	●						
5625	FUJI 65/66	48 x 66	700	53	2	●						
5616	FUJI 74 flexible - flessibile	-	795	48	0,5	●						
5617	FUJI 74 rigid - rigida	-	795	48	2	●						
5619	FUJI 74 old model - modello vecchio	-	793	20	2		●					
5627	FUJI MTP LITOGRAFICA	-	1252	68	0,5	●						
5637	SHINOHARA 52 flexible - flessibile	36 x 50	550	43	0,5	●						
5636	SHINOHARA 52 rigid - rigida	36 x 50	550	43	2	●						
5625	SHINOHARA 66	48 x 66	700	53	2	●						
5618	SHINOHARA 754 V P	-	780	30	1					●		
5620	SHINOHARA 79	-	835	48	0,5	●						

GALLUS

Ref. Codice	Model Descrizione	Machine Size Dim. macchina	Lenght Lunghezza	Width Altezza	Thick. Spess.	Material / Materiale						€
						S+R F+G	Gomma Rubber	Teflon	Plastic Plastica	Other	Altro	
5907	GALLUS R 160	-	222	38	0,5	●						
6026	GALLUS R 180	-	185	27	1					●		
5928	GALLUS R 200	-	250	38	0,5	●						
5909	GALLUS R 200	-	249	32	0,5	●						
5929	GALLUS R 250	-	320	60	0,5	●						
5913	GALLUS TCS 250	-	292	38	0,5	●						
5908	GALLUS R 300	-	362	58	0,5	●						
5930	GALLUS R 2.000	-	375	38	0,5	●						

GESTETNER

Ref. Codice	Model Descrizione	Machine Size Dim. macchina	Lenght Lunghezza	Width Altezza	Thick. Spess.	Material / Materiale						€
						S+R F+G	Gomma Rubber	Teflon	Plastic Plastica	Other	Altro	
5670	GESTETNER 210/211/311/411	-	260	38	1						●	
5671	GESTETNER 213/313/413	-	350	38	1						●	
5672	GESTETNER 152 SF	-	532	43	0,5	●						

GIEBLER

Ref. Codice	Model Descrizione	Machine Size Dim. macchina	Lenght Lunghezza	Width Altezza	Thick. Spess.	Material / Materiale						€
						S+R F+G	Gomma Rubber	Teflon	Plastic Plastica	Other	Altro	
5982	GIEBLER	-	623	22,5	5		●					
6011	GIEBLER	-	550	25	5		●					
6012	GIEBLER 100	-	915	30	0,5	●						
6024	GIEBLER R 55	-	580	25	5		●					

GOEBEL

Ref. Codice	Model Descrizione	Machine Size Dim. macchina	Lenght Lunghezza	Width Altezza	Thick. Spess.	Material / Materiale						€
						S+R F+G	Gomma Rubber	Teflon	Plastic Plastica	Other	Altro	
5940	GOEBEL VARIFORMA	-	560	46	5		●					
5941	GOEBEL MULTIFORMA	-	640	35	5		●					
5951	GOEBEL ECOPRINT	-	590	58	0,5	●						
5981	GOEBEL OPTIFORMA 520	-	611	35	1					●		
5978	GOEBEL M 3300	-	391	35	1					●		

HAMADA

Ref. Codice	Model Descrizione	Machine Size Dim. macchina	Lenght Lunghezza	Width Altezza	Thick. Spess.	Material / Materiale						€
						S+R F+G	Gomma Rubber	Teflon	Plastic Plastica	Other	Altro	
5778	HAMADA 62 CD 2 ND UNIT - 2° GRUPPO	-	315	38	0,5	●						
5779	HAMADA ALFA 66	-	710	58	5		●					
5780	HAMADA 611 1 ST UNIT - 1° GRUPPO	-	335	45	5		●					
5781	HAMADA 611 2 ND UNIT - 2° GRUPPO	-	312	38	0,5	●						
5780	HAMADA DUETTO	-	335	45	5		●					
5784	HAMADA TOPRUNNER	-	276	48	5	●						
5786	HAMADA E47 1 ST UNIT - 1° GRUPPO	-	480	38	0,5	●						
5785	HAMADA E47 2 ND UNIT - 2° GRUPPO	-	487	45	5		●					
5791	HAMADA E47 - C52 E	-	555	38	0,5	●						
5787	HAMADA ALFA 248	-	518	43	0,5	●						
5788	HAMADA BETA 52	-	538	48	0,5	●						

HAMADA

Ref. Codice	Model Descrizione	Machine Size Dim. macchina	Lenght Lunghezza	Width Altezza	Thick. Spess.	Material / Materiale						€
						S+R F+G	Gomma Rubber	Teflon	Plastic Plastica	Other Altro		
5789	HAMADA ALFA 52	-	558	45	5		●					
5797	HAMADA BETA 252/452	-	570	38	0,5	●						
5794	HAMADA 234 C	-	358	48	0,5	●						
5801	HAMADA 500 CD	-	322	46	5		●					
5792	HAMADA 600 CD	-	335	48	0,5	●						
5793	HAMADA 700 E	-	478	45	5		●					
5795	HAMADA 700 CD	-	482	48	0,5	●						
5796	HAMADA 700 CD numbering - numerazione	-	491	53	0,5	●						
5790	HAMADA 700 DX	-	485	58	0,5	●						
5802	HAMADA 800 DX	-	544	45	5		●					
5800	HAMADA 900 CD	-	630	47	5		●					

HAMILTON

Ref. Codice	Model Descrizione	Machine Size Dim. macchina	Lenght Lunghezza	Width Altezza	Thick. Spess.	Material / Materiale						€
						S+R F+G	Gomma Rubber	Teflon	Plastic Plastica	Other Altro		
5987	HAMILTON	-	565	35	5		●					
6013	HAMILTON STEVENS MULTI FEED	-	525	53	0,5	●						
6014	HAMILTON	-	735	58	0,5	●						

HEIDELBERG

Ref. Codice	Model Descrizione	Machine Size Dim. macchina	Lenght Lunghezza	Width Altezza	Thick. Spess.	Material / Materiale						€
						S+R F+G	Gomma Rubber	Teflon	Plastic Plastica	Other Altro		
5005	PLATEN T - STELLA T	26 x 38	380	50	5	●						
5010	PLATEN G - STELLA GT	32 x 46	470	50	5	●						
5015	KS	38 x 52	530	46	1						●	
5020	KSB - KSBA (40x58,5 - 40x57 - 46x57)	46 x 58,5	575	46	1						●	
5021	TYPOGRAPHIC	50 x 70	720	46	1						●	
5025	OHZ	54 x 72	720	46	1						●	
5030	SBG - SB	56 x 77	770	46	1						●	
5031	SBG 2 ND UNIT - 2° GRUPPO	56 x 77	835	46	1						●	
5035	SBB	57 x 82	815	46	1						●	
5040	SBD	64 x 90	880	46	1						●	
5100	TOK	28 x 39	285	42	0,5	●						
5101	QUICKMASTER 46	34 x 46	376	44	4				●			
5105	GTO 46	32 x 46	500	60	0,5	●						
5107	GTO 46 numbering unit - gruppo numerazione	32 x 46	448	40	6						●	

HEIDELBERG

Ref. Codice	Model Descrizione	Machine Size Dim. macchina	Lenght Lunghezza	Width Altezza	Thick. Spess.	Material / Materiale						€
						S+R F+G	Gomma Rubber	Teflon	Plastic Plastica	Other Altro		
5110	GTO 52	36 x 52	565	60	0,5	●						
5112	GTO 52 numbering unit - gruppo numerazione	36 x 52	508	40	6						●	
5205	GTO 52 PVC black - PVC nero	36 x 52	557	25,5	12					●		
5110	PRINTMASTER 52	36 x 52	565	60	0,5	●						
5115	SORM rigid - rigida	52 x 72	790	53	2	●						
5120	SORM flexible - flessibile	52 x 74	790	53	0,5	●						
5122	SORMZ 2 ND UNIT - 2° GRUPPO	52 x 74	754	38	0,5	●						
5135	SORD rigid - rigida	64 x 90	960	53	2	●						
5140	SORD flexible - flessibile	64 x 91,5	960	60	0,5	●						
5145	SORK 65	48 x 65	720	53	2	●						
5150	SOR 82	61 x 82	890	53	2	●						
5200	SORS	72 x 102	1.090	60	0,5	●						
5130	SORS 2 ND UNIT - 2° GRUPPO	72 x 102	1.052	38	0,5	●						
5155	KOR 57	40 x 57	600	53	2	●						
5160	KORD 62	46 x 62	650	53	2	●						
5165	KORD 64	46 x 64	690	53	2	●						
5170	KORS 72	52 x 72	760	53	2	●						
5175	KORA 57	46 x 57	620	53	2	●						
5176	WEB 8 PAGES 12 COLORS	-	566	53	2	●						
5180	MO 65 - MOV P 65	48 x 65	710	60	0,5	●						
5185	MO 65 - MOV P 65 offset blankets	48 x 65	690	60	0,5	●						
5187	MO 65 - MOV P 65 numbering - numerazione	48 x 65	648	52	6						●	
5189	PRINTMASTER 74	52 x 74	826	58	0,5	●						
5193	SPEEDMASTER 52	36 x 52	605	48	0,5	●						
5194	SPEEDMASTER 52 numbering - numerazione	36 x 52	534	28	0,5	●						
5195	SPEEDMASTER 72	52 x 72	790	60	0,5	●						
5201	SPEEDMASTER 72 blankets baldwin	52 x 72	742	58	0,5	●						
5196	SPEEDMASTER 74	52 x 74	820	60	0,5	●						
5197	SPEEDMASTER 74	52 x 74	826	60	0,5	●						
5191	SPEEDMASTER 74 CD	52 x 74	847	45	0,5	●						
5192	SPEEDMASTER 74 CD - UV ink	52 x 74	847	45	3				●			
5200	SPEEDMASTER 102 holes - fori	72 x 102	1.090	60	0,5	●						
5202	SPEEDMASTER 102 CD slots - asole	72 x 102	1.090	60	0,5	●						
5198	SPEEDMASTER 102 - UV ink	72 x 102	1.090	60	3				●			
5204	SPEEDMASTER 102 blankets baldwin	72 x 102	1.042	58	0,5	●						
5130	SPEEDMASTER 102 2 ND UNIT - 2° GRUPPO	72 x 102	1.052	38	0,5	●						
5207	SPEEDMASTER XL 105	74 x 105	1.125	41	0,5	●						
5190	ROTASPEED 102	72 x 102	1.050	60	0,5	●						

KBA (KOENING BAUER - ALBERT)

Ref. Codice	Model Descrizione	Machine Size Dim. macchina	Lenght Lunghezza	Width Altezza	Thick. Spess.	Material / Materiale						€
						S+R F+G	Gomma Rubber	Teflon	Plastic Plastica	Other	Altro	
5219	KBA 417 ROTOOFFSET	-	1.030	73	0,5	●						
5213	KBA ROTOOFFSET COMPACTA 40	-	1.026	68	0,5	●						
5212	KBA RAPIDA 72	-	780	48	0,5	●						
5220	KBA RAPIDA 104	70 x 100	1.130	48	0,5	●						
5210	KBA RAPIDA 105	-	1.140	48	0,5	●						
5211	KBA RAPIDA 142	-	1.510	65	0,5	●						
5229	KBA RAPIDA 162	-	1.710	65	0,5	●						
5222	KBA SRO 72	52 x 72	765	53	0,5	●						
5231	KBA SRO 72	52 x 72	770	51	1				●			
5223	KBA 617 ROTOOFFSET	-	1.516	73	0,5	●						
5226	KBA C 213 ROTOOFFSET	-	1.025	48	0,5	●						
5224	KBA COMPACTA	-	914	68	0,5	●						
5227	KBA REMBRANDT ROTOOFFSET 72	52 x 72	770	51	0,5	●						
5228	KBA REMBRANDT ROTOOFFSET 160	120 x 160	1.700	65	0,5	●						
5730	KBA COMMANDOR 60	-	1.640	68	1				●			
5734	KBA PERFORMA 74	-	803	24	3				●			

KO-PAK

Ref. Codice	Model Descrizione	Machine Size Dim. macchina	Lenght Lunghezza	Width Altezza	Thick. Spess.	Material / Materiale						€
						S+R F+G	Gomma Rubber	Teflon	Plastic Plastica	Other	Altro	
5969	KO-PAK 250	-	280	43	0,5	●						
6005	KO-PAK 400	-	410	43	0,5	●						
6006	KO-PAK 400 for anilox cylinder - per cilindri anilox	-	410	38	0,5	●						

KOMORI

Ref. Codice	Model Descrizione	Machine Size Dim. macchina	Lenght Lunghezza	Width Altezza	Thick. Spess.	Material / Materiale						€
						S+R F+G	Gomma Rubber	Teflon	Plastic Plastica	Other	Altro	
5871	LITHRONE S-29 11 holes - 11 fori	52 x 72	820	35	1				●			
5864	LITHRONE/SPRINT 26 5 holes - 5 fori	48 x 66	727	43	0,5	●						
5857	LITHRONE/SPRINT 26 10 holes - 10 fori	48 x 66	706	48	0,5	●						
5872	LITHRONE/SPRINT 28 6 holes - 6 fori	52 x 72	785	38	0,5	●						
5865	LITHRONE/SPRINT 28 6 holes - 6 fori	52 x 72	785	43	0,5	●						
5858	LITHRONE/SPRINT 28 9 holes - 9 fori	52 x 72	780	43	0,5	●						
5869	LITHRONE/SPRINT 28 11 holes - 11 fori	52 x 72	766	43	0,5	●						
5863	LITHRONE/SPRINT 28 11 holes - 11 fori	52 x 72	766	46	0,5	●						
5866	LITHRONE/SPRINT 28 11 holes - 11 fori	52 x 72	766	48	0,5	●						
5867	LITHRONE/SPRINT 28 11 holes - 11 fori	52 x 72	775	48	0,5	●						

KOMORI

Ref. Codice	Model Descrizione	Machine Size Dim. macchina	Lenght Lunghezza	Width Altezza	Thick. Spess.	Material / Materiale						€
						S+R F+G	Gomma Rubber	Teflon	Plastic Plastica	Other Altro		
5852	LITHRONE 20 8 holes - 8 fori	35 x 50	580	48	0,5	●						
5846	LITHRONE 20 5 holes - 5 fori	35 x 50	590	38	2	●						
5853	LITHRONE 40 8 holes - 8 fori	72 x 103	1.095	53	0,5	●						
5842	LITHRONE 40 12 holes - 12 fori	72 x 103	1.080	53	0,5	●						
5856	LITHRONE 40 13 holes - 13 fori	72 x 103	1.105	50	1				●			
5844	LITHRONE 40 15 holes - 15 fori	72 x 103	1.076	48	0,5	●						
5845	LITHRONE 40 15 holes - 15 fori	72 x 103	1.082	50	0,5	●						
5843	LITHRONE 40 15 holes - 15 fori	72 x 103	1.111	48	0,5	●						
5847	LITHRONE 40 15 horizontal slots - 15 asole orizzontali	72 x 103	1.090	48	0,5	●						
5848	LITHRONE 40 15 vertical slots - 15 asole verticali	72 x 103	1.090	43	0,5	●						
5849	LITHRONE 44 17 holes - 17 fori	83 x 113	1.170	50	5		●					
5841	LITHRONE 44 17 holes - 17 fori	83 x 113	1.170	48	0,5	●						
5854	LITHRONE 44 17 holes - 17 fori	83 x 113	1.210	48	0,5	●						
5850	LITHRONE 50 19 holes - 19 fori	96,5 x 128	1.380	48	0,5	●						
5851	LITHRONE 50 19 vertical slots - 19 asole verticali	96,5 x 128	1.376	48	0,5	●						
5870	SPRINT NEW TYPE	-	720	53	2	●						
5875	SPRINT L 25 C	-	710	43	0,5	●						
5876	SPRINT L 225 B	-	720	53	0,5	●						

KORREX

Ref. Codice	Model Descrizione	Machine Size Dim. macchina	Lenght Lunghezza	Width Altezza	Thick. Spess.	Material / Materiale						€
						S+R F+G	Gomma Rubber	Teflon	Plastic Plastica	Other Altro		
5994	KORREX PRESS	-	546	42	4				●			
6017	KORREX SIMMEL	-	1.036	40	5		●					
5995	KORREX MAX SIMMEL PRESS OFFSET	-	1.090	31	4				●			
6018	KORREX	-	1.040	31	5				●			

MAILÄNDER

Ref. Codice	Model Descrizione	Machine Size Dim. macchina	Lenght Lunghezza	Width Altezza	Thick. Spess.	Material / Materiale						€
						S+R F+G	Gomma Rubber	Teflon	Plastic Plastica	Other Altro		
5680	MAILÄNDER 150 T	-	1.083	48	0,5	●						
5681	MAILÄNDER 160/162	-	1.250	78	0,5	●						
5682	MAILÄNDER 122	-	1.259	78	0,5	●						
5679	MAILÄNDER 140	-	1.080	53	0,5	●						
5683	MAILÄNDER 330 LITOGRAPHIC PRESS	70 x 100	990	78	0,5	●						
5685	MAILÄNDER 330 LITOGRAPHIC PRESS	70 x 100	1.090	78	0,5	●						
5687	MAILÄNDER 330 LITOGRAPHIC PRESS	70 x 100	1.170	78	0,5	●						

MANROLAND

Ref. Codice	Model Descrizione	Machine Size Dim. macchina	Lenght Lunghezza	Width Altezza	Thick. Spess.	Material / Materiale						€
						S+R F+G	Gomma Rubber	Teflon	Plastic Plastica	Other Altro		
5225	PRACTICA 00	35 x 50	555	68	0,5	●						
5230	PRACTICA 00 numbering unit - gruppo numerazione	35 x 50	520	38	0,5	●						
5245	PRACTICA 00 numbering bent - numerazione piegata	35 x 50	520	58	0,5	●						
5235	PRACTICA 01	48 x 66	705	68	0,5	●						
5240	PRACTICA 01 numbering unit - gruppo numerazione	48 x 66	670	38	0,5	●						
5246	PRACTICA 01 numbering bent - numerazione piegata	48 x 66	670	58	0,5	●						
5235	ROLAND 100	48 x 66	705	68	0,5	●						
5253	ROLAND 100	48 x 66	720	65	0,5	●						
5255	ROLAND 200 up to nr. 232 - fino nr. 232	52 x 72	785	65	0,5	●						
5260	ROLAND 200 over nr. 232 - oltre nr. 232	52 x 72	800	65	0,5	●						
5265	ROLAND 200 bicolor - bicolore	52 x 72	790	60	1					●		
5257	ROLAND 300	-	816	60	1					●		
5259	ROLAND MP 300	-	822	68	0,5	●						
5267	ROLAND 500	-	816	60	1					●		
5295	ROLAND 600 lower grinding	72 x 102	1.100	65	0,5	●						
5341	ROLAND 600 upper grinding	72 x 102	1.090	65	0,5	●						
5340	ROLAND 700	70 x 100	1.090	65	0,5	●						
5339	ROLAND 700 13 holes - 13 fori	70 x 100	1.100	53	0,5	●						
5337	ROLAND 700	70 x 100	1.100	55	1					●		
5343	ROLAND 800 V / V W	92 x 130	1.410	65	0,5	●						
5344	ROLAND 800 VI back and front - fronte/retro	100 x 140	1.510	65	0,5	●						
5345	ROLAND 800 VI	100 x 140	1.510	65	0,5	●						
5346	ROLAND 800 VII / VII B	120 x 160	1.710	65	0,5	●						
5336	ROLAND 900	-	1.530	57	1					●		
5258	ROLAND FAVORIT 01	64 x 46	720	65	0,5	●						
5260	ROLAND FAVORIT 02 / OB	52 x 72	800	65	0,5	●						
5270	ROLAND PARVA I	56 x 83	900	65	0,5	●						
5275	ROLAND PARVA II	61 x 92	920	65	0,5	●						
5280	ROLAND PARVA II C	64 x 91,5	995	65	0,5	●						
5285	ROLAND REKORD III	65 x 96,5	1.043	65	0,5	●						
5290	ROLAND REKORD RVK III B	72 x 102	1.070	57	0,5	●						
5295	ROLAND REKORD RZK III B blu series - azzurra	72 x 102	1.100	65	0,5	●						
5305	ROLAND REKORD RWK III B grey series - grigia	72 x 102	1.132	65	0,5	●						
5310	ROLAND ULTRA IV 1 st model - 1° modello	78 x 108	1.145	65	0,5	●						
5315	ROLAND ULTRA IV 1 nd model - 2° modello	78 x 108	1.196	65	0,5	●						
5320	ROLAND ULTRA V	89 x 126	1.336	65	0,5	●						
5322	ROLAND ULTRA V W	92 x 130	1.340	65	0,5	●						
5325	ROLAND ULTRA VI	100 x 140	1.480	65	0,5	●						
5335	ROLAND ULTRA VII / VII B	120 x 160	1.675	65	0,5	●						

MANROLAND

Ref. Codice	Model Descrizione	Machine Size Dim. macchina	Lenght Lunghezza	Width Altezza	Thick. Spess.	Material / Materiale						€
						S+R F+G	Gomma Rubber	Teflon	Plastic Plastica	Other Altro		
5347	M.A.N. 5 GS	-	1.273	68	0,5	●						
5351	M.A.N. ULTRA 127	-	1.412	30	5		●					
5350	M.A.N. G 140	100 x 140	1.540	60	0,5	●						
5352	M.A.N. GS H	-	1.433	78	0,5	●						
5355	M.A.N. G 160	120 x 160	1.749	78	0,5	●						
5360	M.A.N. GS 140	100 x 140	1.412	78	0,5	●						
5365	M.A.N. GS 160	120 x 160	1.614	78	0,5	●						
5366	M.A.N. 06 G	110 x 140	1.555	78	0,5	●						
5364	M.A.N. 06 G	110 x 140	1.570	30	5		●					
5367	M.A.N.	96 x 63	1.020	65	0,5	●						
5368	ROTOMAN WEB OFFSET	96 x 63	1.060	65	0,5	●						
5363	ROTOMAN 40	-	1.040	65	0,5	●						
5362	ROTOMAN C	-	1.039	65	0,5	●						
5369	COLORMAN	-	1.400	65	0,5	●						
5370	LITHO M.A.N.	-	1.552	65	0,5	●						
5371	LITHO M.A.N.	-	1.700	65	0,5	●						
5373	LITHO M.A.N. 64 PAGES - 64 PAGINE	-	1.980	65	0,5	●						
5372	ULTRA M.A.N.	-	1.620	52	3			●				
5729	ROLAND PERLE COLOR	50 x 70	1.000	65	0,5	●						
5988	OCTOMAN	-	745	53	0,5	●						

MILLER

Ref. Codice	Model Descrizione	Machine Size Dim. macchina	Lenght Lunghezza	Width Altezza	Thick. Spess.	Material / Materiale						€
						S+R F+G	Gomma Rubber	Teflon	Plastic Plastica	Other Altro		
5805	MILLER TP 74 S.C. 29 - S.C. 74	52 x 74	820	68	0,5	●						
5810	MILLER TP 92 / TP 32	61 x 82	920	68	0,5	●						
5815	MILLER TP 94 / TP 36	65 x 94	1.022	68	0,5	●						
5820	MILLER TP 38	65 x 97,5	1.092	78	0,5	●						
5825	MILLER TP 104 / TP 41s	72 x 104	1.140	68	0,5	●						

MITSUBISHI

Ref. Codice	Model Descrizione	Machine Size Dim. macchina	Lenght Lunghezza	Width Altezza	Thick. Spess.	Material / Materiale						€
						S+R F+G	Gomma Rubber	Teflon	Plastic Plastica	Other Altro		
5890	MITSUBISHI 1E	50 x 70	784	40	3				●			
5885	MITSUBISHI 1F	50 x 70	778	33	0,5	●						
5891	MITSUBISHI 1F	50 x 70	778	36	3				●			
5889	MITSUBISHI 1G	50 x 70	786	38	0,5	●						
5894	MITSUBISHI 3F	70 x 100	1.186	38	0,5	●						
5886	MITSUBISHI 3F / 3G	70 x 100	1.090	38	0,5	●						
5892	MITSUBISHI 3H	70 x 100	1.100	43	0,5	●						
5887	MITSUBISHI 5F / 5G	90 x 130	1.366	43	0,5	●						
5888	MITSUBISHI 6F / 6G	100 x 140	1.506	43	0,5	●						
5893	MITSUBISHI DIAMOND 3000	70 x 100	1.095	38	0,5	●						

MIYAKOSHI

Ref. Codice	Model Descrizione	Machine Size Dim. macchina	Lenght Lunghezza	Width Altezza	Thick. Spess.	Material / Materiale						€
						S+R F+G	Gomma Rubber	Teflon	Plastic Plastica	Other Altro		
6000	MIYAKOSHI DIR 15	-	465	56	5				●			
6001	MIYAKOSHI MSP 18 MVF double - doppia	-	526	56	5				●			
5962	MIYAKOSHI MSP 18 DVF	-	503	35	5				●			
5963	MIYAKOSHI MSP 18 DVR	-	521	38	5				●			
6002	MIYAKOSHI MVF 20	-	588	60	5				●			
6003	MIYAKOSHI MVF 22	-	637	56	4				●			
5964	MIYAKOSHI	-	526	56	5				●			
5965	MIYAKOSHI MK continuos form - modulo continuo	-	527	50	5		●					

MÜLLER MARTINI

Ref. Codice	Model Descrizione	Machine Size Dim. macchina	Lenght Lunghezza	Width Altezza	Thick. Spess.	Material / Materiale						€
						S+R F+G	Gomma Rubber	Teflon	Plastic Plastica	Other Altro		
5943	MÜLLER MARTINI PRONTO 42 2.200	-	458	38	0,5	●						
5971	MÜLLER MARTINI GRAPH A old - vecchio mod.	-	525	40	3				●			
5944	MÜLLER MARTINI GRAPH A 50/20,5"	-	529	38	0,5	●						
5944	MÜLLER MARTINI GRAPH A 520/R667	-	529	38	0,5	●						
5945	MÜLLER MARTINI GRAPH A 84/32"	-	835	43	0,5	●						
5945	MÜLLER MARTINI PROGRESS 50 20S	-	835	43	0,5	●						
5986	MÜLLER "0" TYPE	-	528	38	0,5	●						

MULTILITH

Ref. Codice	Model Descrizione	Machine Size Dim. macchina	Lenght Lunghezza	Width Altezza	Thick. Spess.	Material / Materiale						€
						S+R F+G	Gomma Rubber	Teflon	Plastic Plastica	Other Altro		
5882	MULTILITH 1250	-	270	20	5		●					
5883	MULTILITH 1250	-	274	48	0,5	●						
5884	MULTILITH 1650	-	330	28	0,5				●			
5881	MULTILITH 1860	-	500	20	5		●					

NEBIOLO

Ref. Codice	Model Descrizione	Machine Size Dim. macchina	Lenght Lunghezza	Width Altezza	Thick. Spess.	Material / Materiale						€
						S+R F+G	Gomma Rubber	Teflon	Plastic Plastica	Other Altro		
5060	SUPEREGERIA	-	590	45	0,2					●		
5065	ATENA	-	780	45	0,2					●		
5070	SATURNIA	-	960	45	0,2					●		
5705	INVICTA 26/226/28/228	-	935	51	1				●			
5706	INVICTA 128	-	830	51	1				●			
5710	INVICTA 32/33/36/36/238	-	1.135	51	1				●			
5715	INVICTA 44	120 x 140	1.165	51	1				●			
5716	INVICTA 44S	120 x 140	1.200	51	1				●			
5720	INVICTA 63-140	120 x 160	1.660	51	1				●			
5721	INVICTA 41 S	72 x 112	1.140	42	0,5	●						
5723	NEBIOLO ROTOOFFSET	120 x 160	1.650	60	3,5			●				
5723	NEBIOLO 63 K/L - COLORA 8000	120 x 160	1.650	60	3,5			●				

PLANETA

Ref. Codice	Model Descrizione	Machine Size Dim. macchina	Lenght Lunghezza	Width Altezza	Thick. Spess.	Material / Materiale						€
						S+R F+G	Gomma Rubber	Teflon	Plastic Plastica	Other Altro		
5440	PLANETA 4	70 x 100	1.060	60	5					●		
5445	PLANETA 6	90 x 127	1.350	60	5					●		
5450	PLANETA 7	100 x 140	1.510	60	5					●		
5455	PLANETA 8/8A	120 x 162	1.710	60	5					●		
5440	PLANETA SUPERVARIANT 4/6	70 x 100	1.060	60	5					●		
5441	PLANETA VARIMAT	-	1.150	68	0,5	●						
5442	PLANETA BRILLANT SP 01	50 x 70	800	65	0,5	●						

ROTAPRINT

Ref. Codice	Model Descrizione	Machine Size Dim. macchina	Lenght Lunghezza	Width Altezza	Thick. Spess.	Material / Materiale						€
						S+R	F+G	Gomma Rubber	Teflon	Plastic Plastica	Other Altro	
5905	ROTAPRINT R14 CS2 continuous form - mod. continuo	-	460	28	1					●		
5906	ROTAPRINT R14 continuous form - modulo continuo	-	466	31	0,5	●						
5910	ROTAPRINT R45K	25 x 35	295	28	1					●		
5915	ROTAPRINT R35K/R36K/R37K	35 x 50	495	28	1					●		
5920	ROTAPRINT R35KV/R36KV/R37KV	35 x 50	538	28	1					●		
5921	ROTAPRINT R35KV/R30SK	35 x 50	514	35	5			●				
5918	ROTAPRINT ENGLISH R38/50 NP	35 x 50	510	34	5			●				

ROTATEK

Ref. Codice	Model Descrizione	Machine Size Dim. macchina	Lenght Lunghezza	Width Altezza	Thick. Spess.	Material / Materiale						€
						S+R	F+G	Gomma Rubber	Teflon	Plastic Plastica	Other Altro	
5931	ROTATEK 100	-	414	43	0,5	●						
5917	ROTATEK MP-150	-	442	58	0,5	●						
5932	ROTATEK 200	-	539	60	0,5	●						
5933	ROTATEK 300 / 400	-	584	53	0,5	●						
5877	ROTATEK SRS - 45 BRAVA	-	492	58	0,5	●						

RYOBI

Ref. Codice	Model Descrizione	Machine Size Dim. macchina	Lenght Lunghezza	Width Altezza	Thick. Spess.	Material / Materiale						€
						S+R	F+G	Gomma Rubber	Teflon	Plastic Plastica	Other Altro	
5640	RYOBI 2.700 / 2.800	-	305	41	5			●				
5641	RYOBI 3.304 H	-	364	40	5			●				
5642	RYOBI 3.200 1 ST UNIT - 1° GRUPPO	-	355	41	5			●				
5643	RYOBI 3.202 2 ND UNIT - 2° GRUPPO	-	353	25	5			●				
5644	RYOBI 480 KA / 500K	-	510	45	5			●				
5646	RYOBI 480 KANP / 500KNP	-	524	35	0,5	●						
5652	RYOBI 500 N	-	504	45	5			●				
5647	RYOBI 510 / 512	-	557	29	5			●				
5654	RYOBI 512	-	560	25	5			●				
5660	RYOBI 520 / 522 / 524	-	573	25	5			●				
5658	RYOBI 520 NP / 522 NP / 524 NP	-	545	48	0,5	●						
5662	RYOBI 530 / 560	-	602	39	5			●				
5661	RYOBI 4502 MCS	-	454	42	5			●				
5664	RYOBI 640	-	736	45	5			●				
5648	RYOBI 662 PF	-	760	42	5			●				
5653	RYOBI 750	-	855	34	5			●				

SAKURAI

Ref. Codice	Model Descrizione	Machine Size Dim. macchina	Lenght Lunghezza	Width Altezza	Thick. Spess.	Material / Materiale						€
						S+R F+G	Gomma Rubber	Teflon	Plastic Plastica	Other	Altro	
5214	SAKURAI OLIVER 72	52 x 72	800	50	5		●					
5215	SAKURAI OLIVER 66	46 x 66	730	50	5		●					
5216	SAKURAI OLIVER 58	44 x 58	620	50	5		●					
5217	SAKURAI OLIVER 6	32 x 48	530	50	5		●					
5218	SAKURAI OLIVER 52	36 x 52	570	50	5		●					
5233	SAKURAI OLIVER 82	-	872	50	5		●					
5238	SAKURAI 575 SD	-	880	50	3		●					
5239	SAKURAI 66 EZ	-	715	50	5		●					

SCHRIBBER

Ref. Codice	Model Descrizione	Machine Size Dim. macchina	Lenght Lunghezza	Width Altezza	Thick. Spess.	Material / Materiale						€
						S+R F+G	Gomma Rubber	Teflon	Plastic Plastica	Other	Altro	
5967	SCHRIBBER typographic continuos form - mod. continuo	-	515	38	0,5	●						
5968	SCHRIBBER 500	-	515	53	0,5	●						
6004	SCHRIBBER 800	-	550	60	0,5	●						

SOLNA

Ref. Codice	Model Descrizione	Machine Size Dim. macchina	Lenght Lunghezza	Width Altezza	Thick. Spess.	Material / Materiale						€
						S+R F+G	Gomma Rubber	Teflon	Plastic Plastica	Other	Altro	
5700	SOLNA C 96	-	1.065	22	3		●					
5701	SOLNA 124	-	700	22	3		●					
5699	SOLNA 125 / 425	-	700	22	3		●					
5698	SOLNA 164 / 566	-	710	22	3		●					
5702	SOLNA 72	72 x 102	810	22	3		●					
5703	SOLNA 240	-	1.160	22	3		●					

STEVENS

Ref. Codice	Model Descrizione	Machine Size Dim. macchina	Lenght Lunghezza	Width Altezza	Thick. Spess.	Material / Materiale						€
						S+R F+G	Gomma Rubber	Teflon	Plastic Plastica	Other	Altro	
6015	STEVENS 4B continuos form - modulo continuo	-	530	48	0,5	●						
6016	STEVENS 3 color WEB	-	1.090	31	4				●			
6027	STEVENS	-	705	48	0,5	●						

TARGET

Ref. Codice	Model Descrizione	Machine Size Dim. macchina	Lenght Lunghezza	Width Altezza	Thick. Spess.	Material / Materiale						€
						S+R F+G	Gomma Rubber	Teflon	Plastic Plastica	Other	Altro	
5722	TARGET I / II WEB mod. 22/23/25	-	1.075	53	0,5	●						
5719	TARGET III 47" / 52"	-	1.075	88	0,5	●						

TIMSONS

Ref. Codice	Model Descrizione	Machine Size Dim. macchina	Lenght Lunghezza	Width Altezza	Thick. Spess.	Material / Materiale						€
						S+R F+G	Gomma Rubber	Teflon	Plastic Plastica	Other	Altro	
6007	TIMSONS MULTIROLL	-	605	70	5				●			
6030	TIMSONS T24	-	549	53	0,5	●						
6008	TIMSONS T32 40"	-	1.080	53	0,5	●						
6009	TIMSONS T32 47"	-	1.258	53	0,5	●						
6010	TIMSONS T32 53"	-	1.410	53	0,5	●						
6028	TIMSONS 135	-	1.510	53	0,5	●						

TISON

Ref. Codice	Model Descrizione	Machine Size Dim. macchina	Lenght Lunghezza	Width Altezza	Thick. Spess.	Material / Materiale						€
						S+R F+G	Gomma Rubber	Teflon	Plastic Plastica	Other	Altro	
5939	TISON FLEXI 10	-	505	45	3			●				
5948	TISON FLEXI 11	-	500	60	0,5	●						
7009	TISON FLEXI 12	-	500	19	5	●						
7001	TISON ST 150	-	460	19	5	●						

VARIOUS / VARIE

Ref. Codice	Model Descrizione	Machine Size Dim. macchina	Lenght Lunghezza	Width Altezza	Thick. Spess.	Material / Materiale						€
						S+R F+G	Gomma Rubber	Teflon	Plastic Plastica	Other	Altro	
5970	C.M.C. CARDANI	-	570	43	0,5	●						
5976	CELLINI CALCOGRAPHIC - CALCOGRAFICA	-	594	48	0,5	●						
5980	BIELOMATIK	-	625	32	5		●					
5991	W&D 212	-	473	48	0,5	●						
5993	DAINIPPON SCREEN KF-123-GL	-	1.100	40	5			●				
6019	DAINIPPON SCREEN KF-124-GL	-	1.100	53	3			●				
5999	UKITA	-	420	43	0,5	●						
7002	HASHIMOTO IMPULSE 22 - SA552 P	-	620	58	0,5	●						

HICKEY REMOVERS

RACCOGLI GRUMI

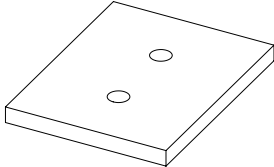
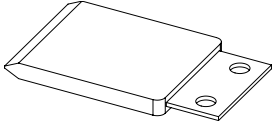
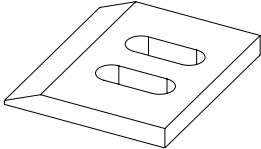
REPLACEMENT FOR SM 102		KOMORI LITHRONE 40/440		MITSUBISHI 3F - DIAMOND	
RICAMBIO PER SM 102		KOMORI LITHRONE 40/440		MITSUBISHI 3F - DIAMOND	
					
5206	RUBBER GOMMA	5868	RUBBER+STEEL GOMMA+FERRO	5895	RUBBER GOMMA

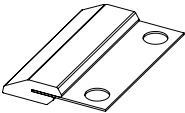
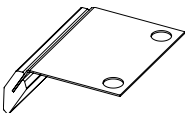
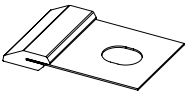
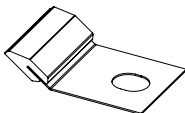
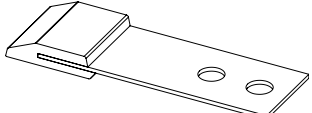
KBA RAPIDA 104/105		KBA RAPIDA 142/162		MILLER	
KBA RAPIDA 104/105		KBA RAPIDA 142/162		MILLER	
 		 			
5237	FLAT - DRITTO	5236	FLAT - DRITTO	5827	65 mm
5232	BEND - PIEGATO	5234	BEND - PIEGATO	5826	82 mm

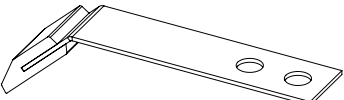
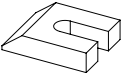
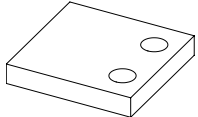
MILLER BEND		ROLAND 600 / REKORD		ROLAND 300	
MILLER PIEGATO		ROLAND 600 / REKORD		ROLAND 300	
					
5828	RUBBER+STEEL GOMMA+FERRO	5291	RUBBER GOMMA	5292	RUBBER GOMMA

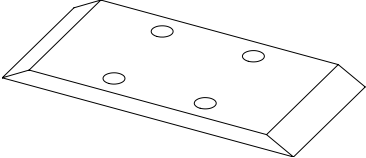
ROLAND 800	
ROLAND 800	
	
5293	RUBBER GOMMA

Hickey remover on measure on request.

A richiesta levacapperi su misura.

DAVIDSON

Ref. Codice	Model Descrizione	Machine Size Dim. macchina	Jacket size Dim. piastra	Thick. Spess.	Material / Materiale					€
					Steel Acciaio	Hard Steel	Brass Ottone	Nylon		
9381	DAVIDSON 501	25 x 35	252 x 391	0,3	●					
9383	DAVIDSON 501	45 x 37	438 x 390	0,3	●					
9382	DAVIDSON 701	35 x 50	503 x 408	0,3	●					

FUJI - SHINOHARA

9360	FUJI / SHINOHARA 52 steel - acciaio	36 x 52	518 x 392	0,3	●					
9359	FUJI / SHINOHARA 52 brass - ottone	36 x 52	519 x 392	0,3			●			
9361	FUJI / SHINOHARA 52 nylon	36 x 52	519 x 392	0,5				●		
9358	FUJI 52 new model - nuovo modello	36 x 52	520 x 367	0,3	●					
9362	FUJI SHINOHARA 66	48 x 66	666 x 516	0,3	●					

HAMADA

9355	HAMADA ALFA 52	35 x 52	513 x 400	0,3	●					
9357	HAMADA ALFA 66	-	654 x 532	0,3	●					

HASHIMOTO

9374	HASHIMOTO 522	-	530 x 435	0,25	●					
-------------	---------------	---	-----------	------	---	--	--	--	--	--

KOENING E BAUER

9363	KOENING & BAUER	72 x 102	1.050 x 743	0,4	●					
-------------	-----------------	----------	-------------	-----	---	--	--	--	--	--

ROTAPRINT

9350	ROTAPRINT R37KV	35 x 50	487 x 348	0,3	●					
-------------	-----------------	---------	-----------	-----	---	--	--	--	--	--

HORAUF

9340	HORAUF COVERING MACHINE	-	710 x 415	0,3	●					
9341	HORAUF COVERING MACHINE old model - tipo vecchio	-	710 x 390	0,3	●					
9342	HORAUF COVERING MACHINE	-	710 x 415	0,3	●					

HEIDELBERG

Ref. Codice	Model Descrizione	Machine Size Dim. macchina	Jacket size Dim. piastra	Thick. Spess.	Material / Materiale					€
					Steel Acciaio	Hard Hiera	Steel Steel	Brass Ottone	Nylon	
9405	QUICKMASTER 46	34 x 46	347 x 496	0,3		●				
9403	GTO 46 steel - acciaio	32 x 46	458 x 393	0,3		●				
9404	GTO 46 brass - ottone	32 x 46	458 x 393	0,3			●			
9402	GTO 46 nylon	32 x 46	458 x 413	0,5				●		
9407	GTO / PRINTMASTER 52 steel - acciaio	36 x 52	518 x 407	0,3		●				
9408	GTO / PRINTMASTER 52 brass - ottone	36 x 52	518 x 407	0,3			●			
9406	GTO / PRINTMASTER 52 nylon	36 x 52	518 x 413	0,5				●		
9410	MO 65 nylon	48 x 65	659 x 547	0,5				●		
9411	MO 65 steel - acciaio	48 x 65	659 x 547	0,3	●					
9412	MO 65 brass - ottone	48 x 65	659 x 547	0,3			●			
9409	SPEEDMASTER 52 steel - acciaio	36 x 52	530 x 390	0,3		●				
9415	SPEEDMASTER 52 brass - ottone	36 x 52	530 x 390	0,3			●			
9417	SPEEDMASTER 52 nylon	36 x 52	530 x 390	0,5				●		
9413	SPEEDMASTER 72 steel - acciaio	52 x 72	738 x 533	0,3	●					
9421	SPEEDMASTER 72 nylon	52 x 72	738 x 533	0,5				●		
9400	SPEEDMASTER 74	52 x 74	753 x 532	0,3	●					
9470	SPEEDMASTER 74 transfer - trasferimento	52 x 74	810 x 530	0,3	●					
9401	SPEEDMASTER 102	72 x 102	1.036 x 710	0,3	●					
9401	SORS	72 x 102	1.036 x 710	0,3	●					
9414	KOR 57	40 x 57	573 x 400	0,5	●					
9416	KORA 57	46 x 57	573 x 454	0,5	●					
9418	KORD 62	46 x 62	625 x 450	0,5	●					
9420	KORD 64	46 x 64	650 x 460	0,5	●					
9422	KORS 72	52 x 72	725 x 520	0,5	●					

KOMORI

9373	SPRINT 25	-	734 x 576	0,3	●					
9375	SPRINT 25 nylon	-	734 x 576	0,5				●		
9370	SPRINT 26	46 x 88	677 x 562	0,3	●					
9376	SPRINT 28	52 x 72	734 x 576	0,4	●					
9377	SPRINT II 28 / SPRINT 28 GS	52 x 72	734 x 586	0,3	●					

MANROLAND

Ref. Codice	Model Descrizione	Machine Size Dim. macchina	Jacket size Dim. piastra	Thick. Spess.	Material / Materiale					€
					Steel Acciaio	Hard Hiera	Steel Steel	Brass Ottone	Nylon	
9423	PRACTICA 00 up to nr. 134 - fino matr. 134	35 x 50	509 x 393	0,3	●					
9424	PRACTICA 00 over nr. 134 - oltre matr. 134 / steel - acciaio	35 x 50	510 x 385	0,3	●					
9429	PRACTICA 00 over nr. 134 - oltre matr. 134 / brass - ottone	35 x 50	510 x 385	0,3				●		
9458	PRACTICA 00 over nr. 134 - oltre matr. 134 / nylon	35 x 50	510 x 385	0,5					●	
9455	PRACTICA 00 two colors (bend 45°) - bicolore (piega 45°)	35 x 50	510 x 385	0,3	●					
9425	PRACTICA 01 up to nr. 163 - fino matr. 163	48 x 66	660 x 492	0,3	●					
9426	PRACTICA 01 over nr. 163 - oltre matr. 163	48 x 66	660 x 473,5	0,3	●					
9459	ROLAND RVF OB	48 x 66	730 x 608	0,3	●					

RYOBI

9468	RYOBI 520	-	482 x 362	0,3		●				
9492	RYOBI 520 NP	-	525 x 415	0,3		●				
9469	RYOBI 750	50 x 70	820 x 548	0,5	●					

SAKURAI

9365	OLIVER 52	36 x 52	525 x 408	0,3	●					
9366	OLIVER 6	32 x 48	485 x 389	0,3	●					
9367	OLIVER 58 steel - acciaio	44 x 58	580 x 495	0,3	●					
9371	OLIVER 58 brass - ottone	44 x 58	580 x 495	0,5				●		
9368	OLIVER 66	46 x 66	668 x 543	0,3	●					
9369	OLIVER 72	52 x 72	725 x 585	0,3	●					

TOKO

9364	TOKO	-	315 x 496	0,2	●					
-------------	------	---	-----------	-----	---	--	--	--	--	--

Super Blue Original Nets

Ref. Codice	Description Descrizione	Measure Misura	€
9714	SUPERBLU 102 (100x85 - 43.0"x36.0") SUPERBLU 102 (100x85)	6/ROLL - 6 TELI	

PrintGuardPlus Jacket

**SILICONE COATED ANTI MARKING TRANSFERT JACKETS (ORANGE)
CAMICIE SILICONATE PER CILINDRI DI TRASFERIMENTO (ARANCIONI)**

Ref. Codice	Description Descrizione	€
9810	HEIDELBERG SM 102 RIVETS & LOOPS - BOTTONI+ASTINA POST 1994/5 - DOPO 5/1994	
9812	HEIDELBERG SM 102 LOOPS & LOOPS - ASTINA+ASTINA PRE 1994/5 - PRIMA 5/1994	
9814	HEIDELBERG SM 102 DELIVERY - USCITA 1.024 x 762 mm	
9816	HEIDELBERG SM 102 DELIVERY - USCITA 1.024 x 756 mm	
9818	HEIDELBERG SM 102 DELIVERY - USCITA 1.024 x 705 mm	
9820	HEIDELBERG SM 74	
9822	HEIDELBERG SM 74 DELIVERY (LOW PILE ONLY) - USCITA (SOLO BASSA PILA)	
9824	HEIDELBERG SM 72	
9826	HEIDELBERG MO	
9828	HEIDELBERG SM 52	
9830	HEIDELBERG SM 52 DELIVERY - USCITA	
9832	HEIDELBERG GTO 52	

PrintGuard & PrintGuardPlus Film

**ANTI MARKING FILM
PELLICOLA IDROPELENTE**

Ref. Codice	Description Descrizione	Measure Dimensioni	€
9840	PrintGuard TYPE S WHITE NON ADHESIVE FOR GENERAL PAPER PrintGuard TIPO S BIANCO NON ADESIVO PER CARTA	0,2 x 1.054 mm each meter - ogni metro	
9842	PrintGuard TYPE S WHITE ADHESIVE FOR GENERAL PAPER PrintGuard TIPO S BIANCO ADESIVO PER CARTA	0,2 x 1.054 mm each meter - ogni metro	
9844	PrintGuard TYPE L WHITE NON ADHESIVE FOR CARD PrintGuard TIPO L BIANCO NON ADESIVO PER CARTONE	0,3 x 1.054 mm each meter - ogni metro	
9846	PrintGuard TYPE L WHITE ADHESIVE FOR CARD PrintGuard TIPO L BIANCO ADESIVO PER CARTONE	0,3 x 1.054 mm each meter - ogni metro	
9850	PrintGuardPlus TYPE S ORANGE NON ADHESIVE FOR GENERAL PAPER PrintGuardPlus TIPO S ARANCIONE NON ADESIVO PER CARTA	0,2 x 1.054 mm each meter - ogni metro	
9852	PrintGuardPlus TYPE S ORANGE ADHESIVE FOR GENERAL PAPER PrintGuardPlus TIPO S ARANCIONE ADESIVO PER CARTA	0,2 x 1.054 mm each meter - ogni metro	
9854	PrintGuardPlus TYPE L ORANGE NON ADHESIVE FOR CARD PrintGuardPlus TIPO L ARANCIONE NON ADESIVO PER CARTONE	0,3 x 1.054 mm each meter - ogni metro	
9856	PrintGuardPlus TYPE L ORANGE ADHESIVE FOR CARD PrintGuardPlus TIPO L ARANCIONE ADESIVO PER CARTONE	0,3 x 1.054 mm each meter - ogni metro	

ALBERT

Ref. Codice	Model Descrizione	Machine Size Dim. macchina	Jacket size Dim. piastra	Thick. Spess.	Material / Materiale					€
					Steel Acciaio	Hard Steel	Brass	Other	Nylon	
9480	ALA EXP.	38 X 57	580 x 390	0,8	●					
9481	ALA	40 x 58	585 x 405	0,8	●					
9382	GRALA	52 x 72	700 x 500	0,8	●					
9483	GRALA EXP.	56 x 76	760 x 550	0,8	●					
9384	GRALA	56 x 80	775x 540	0,8	●					
9485	PRESIDENT	70 x 101	1.020 x 690	0,8	●					
9486	PRESIDENT G.M.	75 x 105	1.050 x 750	0,8	●					
9488	SENATOR	84 x 112	1.130 x 820	0,8	●					

HEIDELBERG

9427	PLATEN T - STELLA T	26 x 38	362 x 260	0,8		●				
9428	PLATEN GT - STELLA GT	32 x 46	451 x 335	0,8		●				
9471	BED (CHASE) T - CONTROPRESSIONE T	26 x 38	363 x 253	0,8	●					
9472	BED (CHASE) GT - CONTROPRESSIONE GT	32 x 46	452 x 327	0,8	●					
9490	PLATEN GT - STELLA GT 2 mm	32 x 46	453 x 311	2,0		●				
9492	PLATEN GT - STELLA GT 3 mm	32 x 46	453 x 311	3,0		●				
9430	KS	38 x 52	525 x 375	0,8	●					
9431	KSBA	46 x 57	570 x 450	0,8		●				
9432	KSBA	46 x 58,5	585 x 450	0,8		●				
9433	KSB	40 x 58,5	583 x 397	0,8		●				
9434	KSB	40 x 57	570 x 400	0,8		●				
9435	KSD	46 x 64	650 x 460	0,8		●				
9436	OHZ - S	54 x 72	720 x 535	0,8		●				
9437	SBG 0,6 mm	56 x 77	770 x 560	0,6	●					
9438	SBG 0,8 mm	56 x 77	770 x 560	0,8		●				
9460	SBG - SB	54 x 77	770 x 550	0,8		●				
9439	HEIDELBERG OLD	51 x 70	700 x 513	0,8		●				
9440	SBB	57 x 82	820 x 560	0,8		●				
9441	SBD	64 x 89	885 x 632	0,8	●					
9442	SBD	64 x 90	895 x 632	0,8	●					

JOHANNISBERG

Ref. Codice	Model Descrizione	Machine Size Dim. macchina	Jacket size Dim. piastra	Thick. Spess.	Material / Materiale					€
					Steel Acciaio	Hard Steel	Brass	Aluminum Alluminio	Nylon	
9461	JOHANNISBERG	56 x 76	745 x 520	0,8	●					
9462	JOHANNISBERG SELEKTA	57 x 80	820 x 580	0,8	●					
9463	JOHANNISBERG 82	58 x 84	820 x 600	0,8	●					
9465	JOHANNISBERG S 104	75 x 104	1.050 x 730	0,8	●					

KOENING & BAUER

9474	KOENING & BAUER CONDOR	70 x 102	1.000 x 710	0,8	●					
-------------	------------------------	----------	-------------	-----	---	--	--	--	--	--

NEBIOLO

9443	EGERIA	40 x 56	560 x 400	0,8	●					
9444	SUPER EGERIA	45 x 57	580 x 415	0,8	●					
9466	SUPER EGERIA	45 x 57	580 x 435	0,8	●					
9445	ATENA	56 x 79	790 x 550	0,8	●					
9446	URANIA	76 x 112	1.110 x 790	0,8	●					
9447	URANIA G.M.	80 x 112	1.140 x 785	0,8	●					
9448	SATURNIA	65 x 96	970 x 630	0,8	●					
9449	MUSSANO E SISTO	40 x 65	575 x 375	0,8	●					
9450	MUSSANO E SISTO INTREPIDA ULTRA	46 x 65	692 x 488	0,8	●					
9451	MUSSANO E SISTO UNIGRAF	52 X 72	720 X 512	0,8	●					
9452	NEBIOLO RAPIDA DI LUSO	50 x 70	735 x 510	0,8	●					
9453	BRILLI E FERRANDO	50 x 70	750 x 520	0,8	●					
9454	AIRUNDO	35 x 50	540 x 395	0,8	●					
9456	PLANETA (VICTORIA 1040)	70 x 100	1.047 x 740	0,8	●					

INK FOUNTAIN BLADES WITH SEGMENTS

LAME DEL CALAMAIO A SETTORI

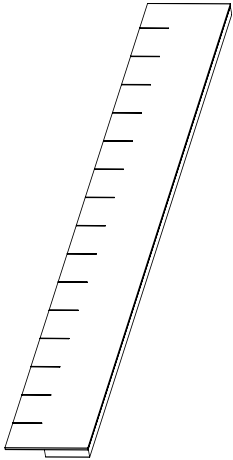
	Ref. Codice	Model Descrizione	Size Dimensioni	€
	9546	HEIDELBERG GTO 46	452 x 86 mm	
9452	HEIDELBERG GTO 52	512 x 94 mm		
9560	HEIDELBERG MO 65	662 x 129,5 mm		
9557	HEIDELBERG SORM 72	730 x 175 mm		
9156	HEIDELBERG SPEEDMASTER 74	747 x 135 mm		
9558	HEIDELBERG SPEEDMASTER 102	1.030 x 175 mm		
9162	ROLAND PRACTICA 00	730 x 145 mm		
9164	ROLAND 200	510 x 125 mm		
9559	ROLAND	1.030 x 143 mm		
9568	M.A.N. GS 140	1.430 x 152 mm		
9577	LITHOMAN 48	1.502 x 150 mm		
9579	SAKURAI OLIVER 72	746 x 114 mm		
9583	SAKURAI OLIVER 252 RP	596 x 112 mm		
9152	KOMORI SPRINT 28	734 x 106 mm		

INK FOUNTAIN BLADES

LAME DEL CALAMAIO

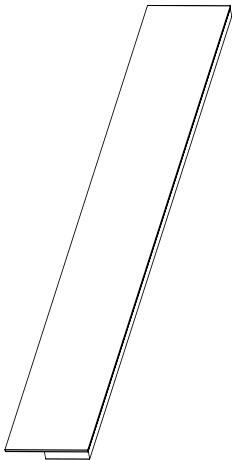
	Ref. Codice	Model Descrizione	Size Dimensioni	€
	9581	HEIDELBERG PLATEN T - STELLA T	375 x 101,5 mm	
9447	HEIDELBERG GTO 46	452 x 86 mm		
9553	HEIDELBERG GTO 52	512 x 94 mm		
9561	HEIDELBERG MO 65	662 x 129,5 mm		
9155	HEIDELBERG KORD 64	670 x 102 mm		
9556	HEIDELBERG KORS 72	740 x 103 mm		
9548	HEIDELBERG SORM 72	730 x 175 mm		
9584	HEIDELBERG SORM 72	730 x 118 mm		
9168	HEIDELBERG SPEEDMASTER 74	747 x 135 mm		
9562	HEIDELBERG SPEEDMASTER 102	1.030 x 175 mm		
9563	ROLAND PRACTICA 00	510 x 125 mm		
9564	ROLAND PRACTICA 01	661 x 125 mm		
9565	ROLAND 200	730 x 145 mm		
9165	ROLAND FAVORIT RF-OB	730 x 110 mm		
9569	ROLAND	1.030 x 143 mm		
9575	M.A.N. GS 140	1.502 x 152 mm		
9578	LITHOMAN 48	1.430 x 150 mm		
9554	FUJI 50	530 x 85 mm		
9582	FUJI 52	530 x 98 mm		
9153	KOMORI SPRINT 28	734 x 106 mm		
9172	KOMORI LITHRONE 40	1.085 x 176 mm		

INK DUCT STOP PLATES

SPALLE DEL CALAMAIO

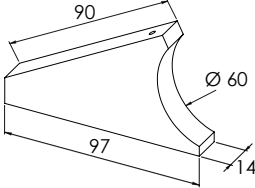
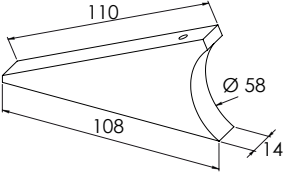
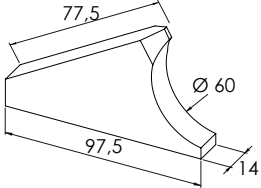
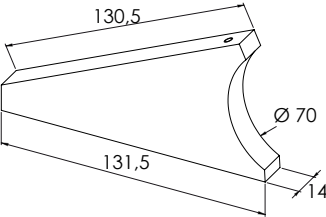
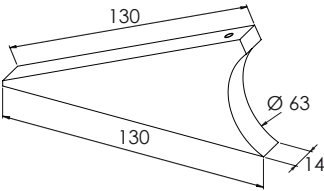
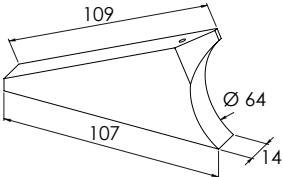
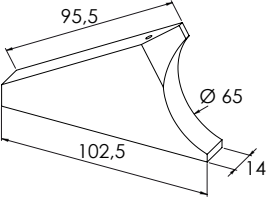
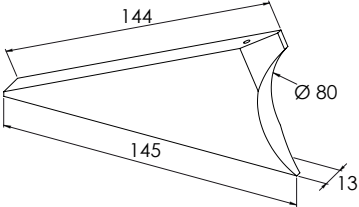
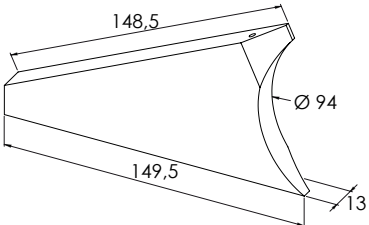
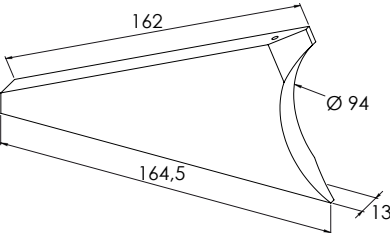
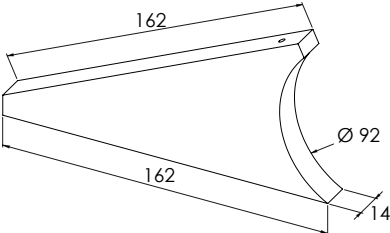
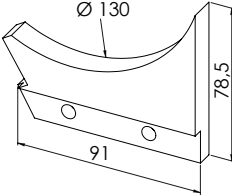
HEIDELBERG GTO NO CPTRONIC		HEIDELBERG GTO CPC + CPTRONIC		HEIDELBERG GTO NO CPTRONIC	
					
9502	RIGHT & LEFT DESTRO e SINISTRO	9619	RIGHT & LEFT DESTRO e SINISTRO	9635	RIGHT & LEFT DESTRO e SINISTRO
HEIDELBERG MO		HEIDELBERG MO CPC		HEIDELBERG SPEEDMASTER 52 CPC + CPTRONIC	
					
9574	RIGHT & LEFT DESTRO e SINISTRO	9503	RIGHT & LEFT DESTRO e SINISTRO	9509	RIGHT & LEFT DESTRO e SINISTRO
HEIDELBERG SPEEDMASTER 52 NO CPC		HEIDELBERG SPEEDMASTER 74		HEIDELBERG SPEEDMASTER 74 CD	
					
9636	RIGHT & LEFT DESTRO e SINISTRO	9504	RIGHT & LEFT DESTRO e SINISTRO	9637	RIGHT & LEFT DESTRO e SINISTRO
HEIDELBERG SPEEDMASTER 72 / 102		HEIDELBERG SPEEDMASTER 72 CD / 102 CD		HEIDELBERG WEB 8/16	
					
9505	RIGHT & LEFT DESTRO e SINISTRO	9515	RIGHT & LEFT DESTRO e SINISTRO	9572	RIGHT & LEFT DESTRO e SINISTRO

Sold with scraper cleaner, scraper clenaer holder and strip

Completi di raschietto, premiraschietto e strisce adesive

INK DUCT END BLOCKS

SPALLE DEL CALAMAIO

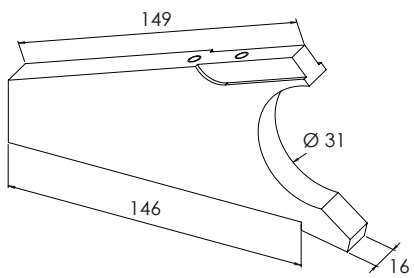
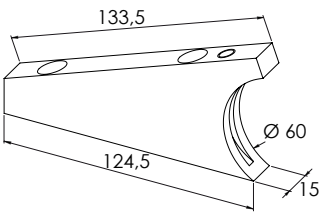
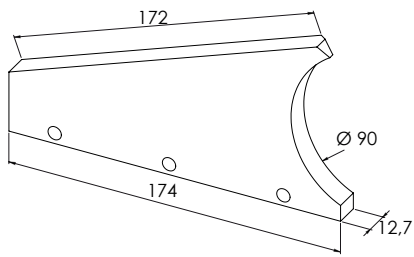
ROLAND 200 (BAKELITE)		TISON (CAST IRON / GHISA)		AURELIA 700 (BRONZE / BRONZO)	
					
9585	RIGHT & LEFT DESTRO e SINISTRO	9576	RIGHT & LEFT DESTRO e SINISTRO	9587	RIGHT & LEFT DESTRO e SINISTRO

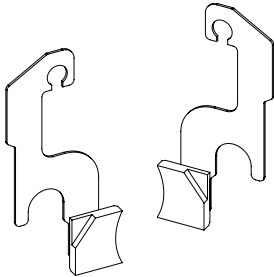
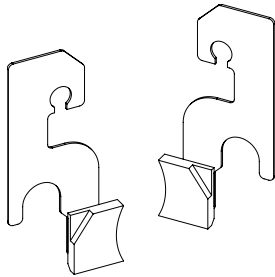
PRINTMASTER END BLOCKS SPALLETTE PRINTMASTER		QUICKMASTER END BLOCKS SPALLETTE QUICKMASTER	
			
9617	RIGHT & LEFT DESTRO e SINISTRO	9618	RIGHT & LEFT DESTRO e SINISTRO

SCRAPER

RASCHIETTI

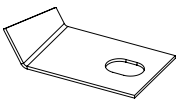
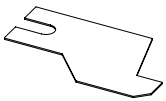
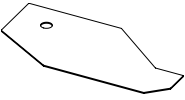
	Ref. Codice	Model Descrizione	Pieces per box Conf. da	Price for Prezzo per	€
	9540	SCRAPER HOLDER FOR INK DUCT BLOCKS PREMIRASCHIETTO PER SPALLE CALAMAI	2	BOX CONF.	
	8001	SCRAPER CLEANER FOR DUCT ROLLER HEIDELBERG RASCHIETTO PER RULLI CALAMAI HEIDELBERG	50	BOX CONF.	
	8002	SCRAPER CLEANER FOR DUCT ROLLER HEIDELBERG WEB RASCHIETTO PER RULLI CALAMAI HEIDELBERG WEB	50	BOX CONF.	

INK DUCT FOILS

COPRICALAMAI

Ref. Codice	Model Descrizione	Size Dimensioni	Thickness Spessore	Foils Fogli	€
9706	QUICKMASTER	358 x 200 mm	190 µm	100	
9705	GTO 52 / SPEEDMASTER 52	547 x 200 mm	190 µm	100	
9720	GTO 52 CD / SPEEDMASTER 52 CD	547 x 196 mm	190 µm	100	
9702	SPEEDMASTER 72/74 - SORM	775 x 232 mm	190 µm	100	
9721	SPEEDMASTER 72/74 CD	775 x 228 mm	190 µm	100	
9701	SPEEDMASTER 102	1.067 x 232 mm	190 µm	100	
9722	SPEEDMASTER 102 CD	1.067 x 228 mm	250 µm	100	
9704	MO	677 x 200 mm	190 µm	100	
9703	SO	935 x 232 mm	190 µm	100	
9707	WEB 8	548 x 260 mm	190 µm	50	
9708	WEB 16 / H 600	1.002 x 260 mm	190 µm	50	
9709	M 110 C	740 x 260 mm	190 µm	50	
9711	ALL 72/74	775 x 232 mm	190 µm	50	
9710	ALL 102	1.067 x 232 mm	190 µm	50	

INK DUCT TAPES

BIADESIVI PER CALAMAI

Ref. Codice	Model Descrizione	€
9719	SCOTCH TAPE FOR INK DUCT END BLOCKS - 15 mm x 25 m SCOTCH BIADESIVO PER SPALLE CALAMAIO - 15 mm x 25 m	
9712	BI-ADHESIVE PROTECTIVE FOIL - 70 mm x 25 m ROTOLO BIADESIVO A 2 BANDE PER CALAMI CON CPC - 70 mm x 25m	
9713	SELF-ADHESIVE FOAM - 20 m SCHIUMA AUTOADESIVA - 20 m	
9700	BI-ADHESIVE STRIP FOR INK DUCT END BLOCKS - 15x150 mm (PRICE FOR BOX 10 PIECES) STRISCE BIADESIVE PER SPALLE CALAMAIO - 15x150 mm (PREZZO PER CONFEZIONE DA 10 PEZZI)	

CYLINDER WASHING BAR FOR MITSUBISHI

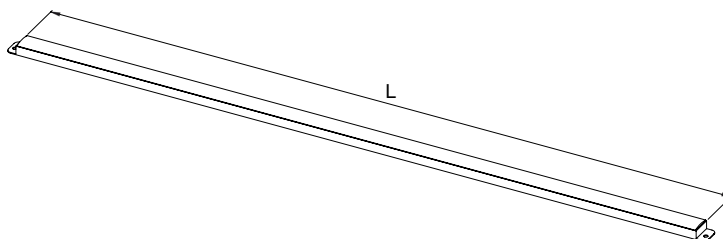

BARRE LAVACILINDRO MITSUBISHI



Ref. Codice	Description Descrizione	Measure (L) Misura (L)	€
4502	PRESSURE CYLINDER WASHING BAR BARRA LAVACILINDRO	750 mm	
4501	PRESSURE CYLINDER WASHING BAR BARRA LAVACILINDRO	1.050 mm	
4504	PRESSURE CYLINDER WASHING BAR BARRA LAVACILINDRO	1.087 mm	
4500	PRESSURE CYLINDER WASHING BAR BARRA LAVACILINDRO	1.320 mm	
4503	PRESSURE CYLINDER WASHING BAR BARRA LAVACILINDRO	1.470 mm	

PARTS FOR HEIDELBERG GTO

RICAMBI PER GTO

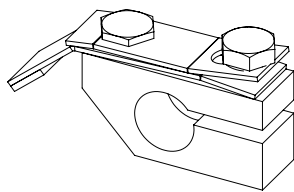
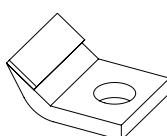
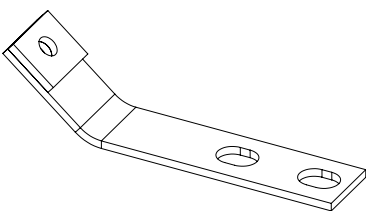
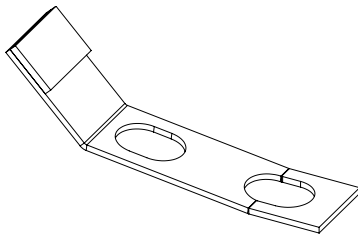
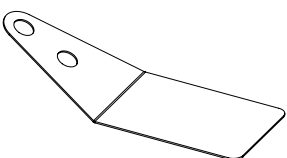
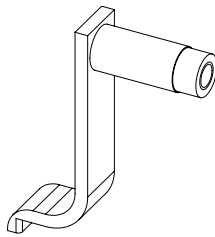
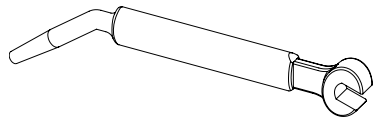
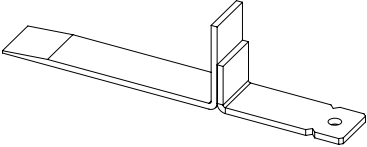
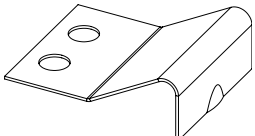
SPEED CLAMPS KIT		BLANKET BAR KIT		DELIVERY GRIPPER BAR	
KIT BARRE CHIUSURA RAPIDA		KIT BARRE CAUCCIU'		BARRA / PINZA USCITA	
					
4551	GTO 46				
4553	GTO 46 MULTICOLOR	9526	GTO 46	9570	GTO 46
4552	GTO 52	9527	GTO 52	9571	GTO 52
DELIVERY GRIPPER KIT		CYLINDER GRIPPER		FEEDER GRIPPER	
PINZA USCITA COMPLETA		PINZA CILINDRO		PINZA METTIFOGLIO	
					
9529	46 & 52 - each piece 46 e 52 - ogni pezzo	9510	46 & 52 - each piece 46 e 52 - ogni pezzo	9521	box 2 - each piece conf. 2 pz - ogni pezzo
DELIVERY GRIPPER		SPRING PLATE FOR SHEET SMOOTHERS		FRONT GUIDE	
PINZA USCITA		GUIDA FOGLIO		REGISTRO	
					
9522	box 2 - each piece conf. 2 pz - ogni pezzo	9507	box 10 - each piece conf. 10 pz - ogni pezzo	9533	46 & 52 - each piece 46 e 52 - ogni pezzo
PLATE SPANNER (11 mm)		HOLD DOWN STRAP		SPRING CLIP FOR HOLD DOWN STRAPS	
CHIAVE 11 mm CON PERNO		GUIDA FERMA-FOGLI USCITA		MOLLA PER GUIDA FERMA-FOGLI	
					
9573	46 & 52 - each piece 46 e 52 - ogni pezzo	9523	46 & 52 - each piece 46 e 52 - ogni pezzo	9524	46 & 52 - each piece 46 e 52 - ogni pezzo

PARTS FOR HEIDELBERG GTO

RICAMBI PER GTO

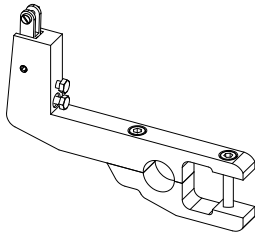
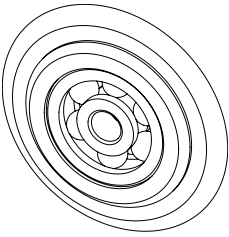
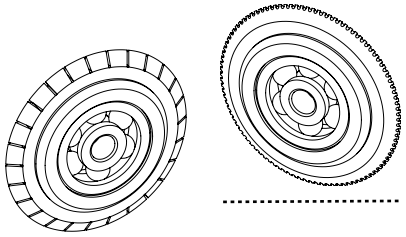
PERFORATING ARM		SMALL WHEEL FOR GTO		SMALL WHEEL FOR GTO	
SUPPORTO PERFORATORE		ROTELLE PER GTO		ROTELLE PER GTO	
					
9631	GTO 52 - each piece	9041	CREASING / CORDONAT.	9043	26 THEET - 26 DENTI
	GTO 52 - ogni pezzo	9042	CUT / TAGLIO	9044	MICRO

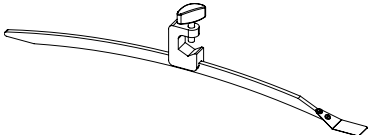
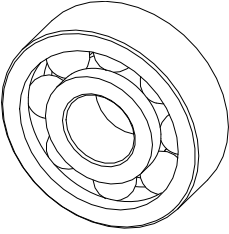
COMPLETE SHEET SMOOTHER		BEARING FOR GTO / MO	
GUIDA-FOGLIO COMPLETO		CUSCINETTI PER GTO / MO	
			
9622	GTO 46	9050	Ø 28 x 8 x Ø 12 mm
9624	GTO 52	9051	Ø 25 x 8 x Ø 10 mm

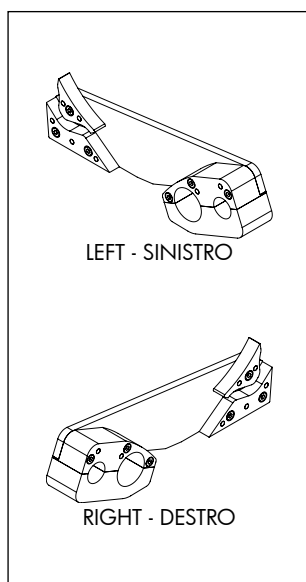

NUMBERING CAMS			
CAMME COMANDO NUMERATORI			
Ref. Codice	Model	Descrizione	€
9640	GTO 52	RIGHT / DESTRO	
9641	GTO 52	LEFT / SINISTRO	
9642	GTO 52	DOUBLE RIGHT / DOPPIO DESTRO	
9643	GTO 52	DOUBLE LEFT / DOPPIO SINISTRO	
9644	GTO 46	RIGHT / DESTRO	
9645	GTO 46	LEFT / SINISTRO	
9646	GTO 46	DOUBLE RIGHT / DOPPIO DESTRO	
9647	GTO 46	DOUBLE LEFT / DOPPIO SINISTRO	

PARTS FOR HEIDELBERG PLATEN

RICAMBI PER STELLA

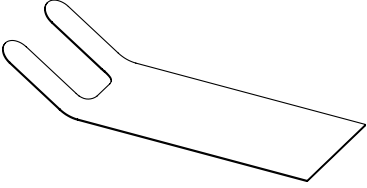
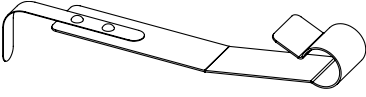
WINDMILL GRIPPER ARM		MOLLA CENTRALE		SIDE SPRING	
PINZA		CENTRAL TONGUE		MOLLA LATERALE	
					
9500	T - 26x38 (10"x15")	9518	box 5 - each piece	9520	box 10 - each piece
9501	GT - 32x46 (13"x18")		conf. 5 pz - ogni pezzo		conf. 10 pz - ogni pezzo

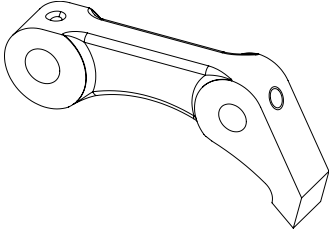
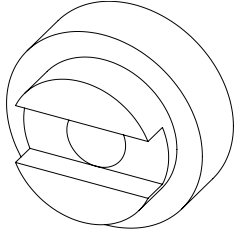
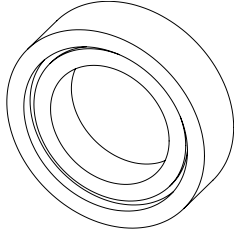

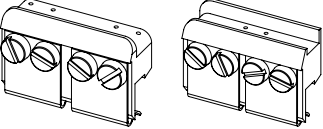
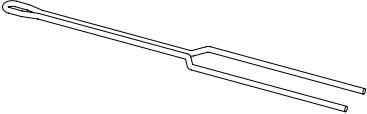
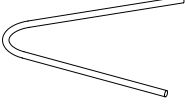
HOOK UP PILE		BLACK ROLL FOR ROLLERS		PRESSURE RING	
GANCIO ALZAPILA		ROTELLA NERA PER RULLI		ANELLO DI PRESSIONE	
					
9541	T & GT - each piece T e GT - ogni pezzo	9126	box 4 - each piece conf. 4 pz - ogni pezzo	9140	T & GT - each piece T e GT - ogni pezzo

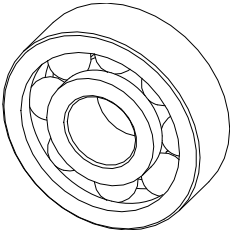
BRASS GUIDER		PINS (box 10 - price for box)		OPEN PINS	
SQUADRETTA OTTONE		SPILLI (conf. 10 pz - prezzo per conf.)		SPILLI DIVARICATI	
					
9120	RIGHT & LEFT DESTRA e SINISTRA	9130	A - L = 37 mm	9138	box 10 - price for box conf. 4 pz - prezzo per conf.
		9132	B - L = 45 mm		
		9134	C - L = 56 mm		
		9136	D - L = 68 mm		

BEARING FOR ROLLERS	
CUSCINETTO PER RULLI	
	
9125	T & GT - each piece T e GT - ogni pezzo

SPARE PARTS FOR TYPOGRAPHIC

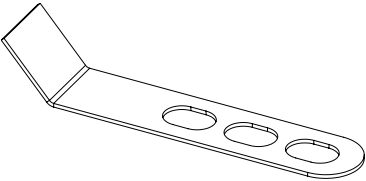
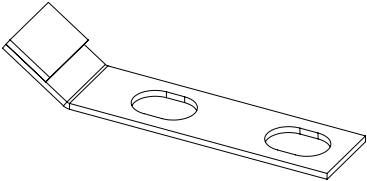
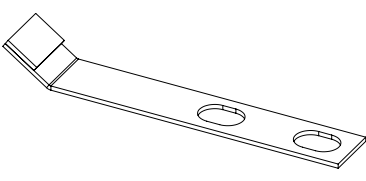
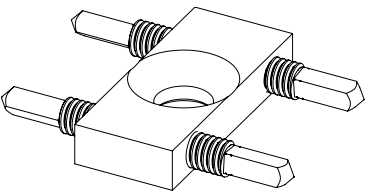
PARTI PER TIPOGRAFICHE

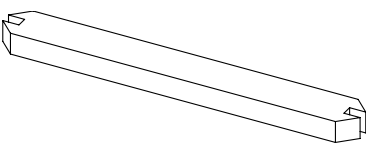
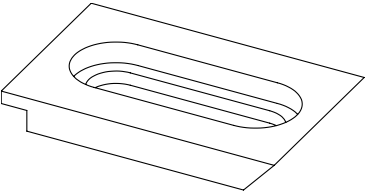
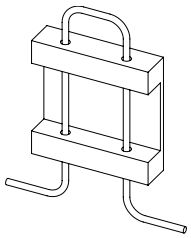
GRIPPER FOR FEEDER		GRIPPER FOR DELIVERY CHAIN		GRIPPER FOR CARRIAGE	
PINZETTA METTIFOGLIO		PINZETTA CATENA USCITA		PINZETTA CARRO USCITA	
					
9543	box 4 - each piece conf. 4 pz - ogni pezzo	9544	box 10 - each piece conf. 10 pz - ogni pezzo	9545	box 10 - each piece conf. 10 pz - ogni pezzo
COMPLETE CLAMP FOR BLOCKS		SCREW FOR CLAMP FOR BLOCKS		KEY FOR CLAMP FOR BLOCKS	
MORSETTO COMPLETO PER CLICHE'		VITI PER MORSETTO CLICHE'		CHIAVE PER MORSETTO CLICHE'	
					
9530	box 20 - each piece conf. 20 pz - ogni pezzo	9531	box 20 - each piece conf. 20 pz - ogni pezzo	9532	box 20 - each piece conf. 20 pz - ogni pezzo
CLAMP FOR BLOCKS		GUIDER FOR CREASING			
STAFFA PER CLICHE'		SQUADRETTA A NASTRO			
					
9542	each piece ogni pezzo	9634	each piece ogni pezzo		

SHEET SEPARATORS

SEPARAFOGLI

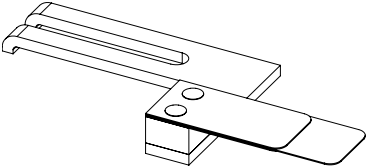
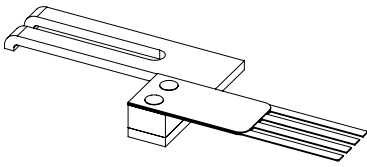
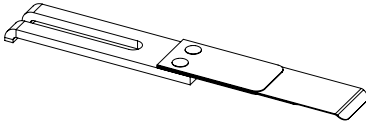
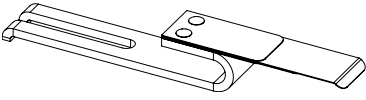
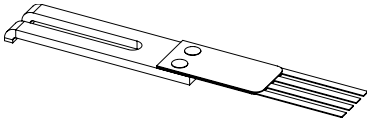
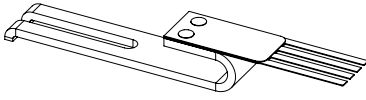
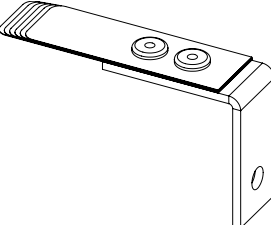
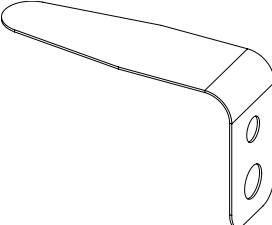
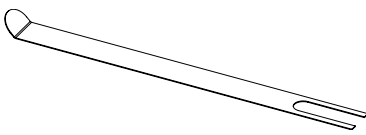
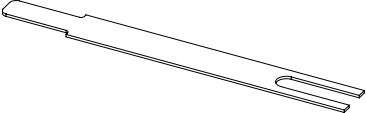
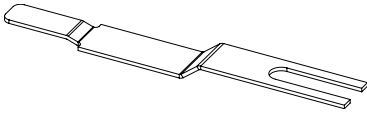
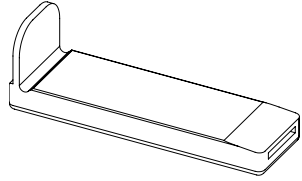
SHEET SEPARATOR SM 72		SHAPED SHEET SEPARATOR SM 72		SHEET SEPARATOR SPEEDMASTER	
SEPARAFOGLIO SM 72		SEPARAFOGLIO A PETTINE SM 72		SEPARAFOGLIO SPEEDMASTER	
					
9549	RIGHT & LEFT DESTRO e SINISTRO	9550	RIGHT & LEFT DESTRO e SINISTRO	9715	box 10 - each piece conf. 10 pz - ogni pezzo
SHEET SEPARATOR SPEEDMASTER		SHEET SEPARATOR SPEEDMASTER		SHEET SEPARATOR SPEEDMASTER	
SEPARAFOGLIO SPEEDMASTER		SEPARAFOGLIO SPEEDMASTER		SEPARAFOGLIO SPEEDMASTER	
					
9716	box 10 - each piece conf. 10 pz - ogni pezzo	9717	box 10 - each piece conf. 10 pz - ogni pezzo	9718	box 10 - each piece conf. 10 pz - ogni pezzo
SHEET SEPARATOR KBA RAPIDA		SHEET SEPARATOR KBA RAPIDA		SHEET SEPARATOR HEIDELBERG	
SEPARAFOGLIO KBA RAPIDA		SEPARAFOGLIO KBA RAPIDA		SEPARAFOGLIO HEIDELBERG	
					
4731	L = 50 mm	4733	box 10 - each piece conf. 10 pz - ogni pezzo	9506	L = 120 mm
4732	L = 45 mm			9517	L = 145 mm
				9514	L = 170 mm
FLAT RUBBER HOLDER		SHAPED RUBBER HOLDER		RUBBER HOOD	
PORTAGOMMINO DRITTO		PORTAGOMMINO PIEGATO		GOMMINO SEPARAFOGLIO	
					
9508	L = 85 mm	9513	L = 95 mm	9516	box 20 - each piece conf. 20 pz - ogni pezzo
9512	L = 110 mm	9511	L = 150 mm		

SHEET SEPARATORS

SEPARAFOGLI

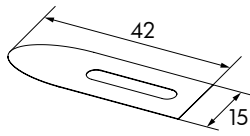
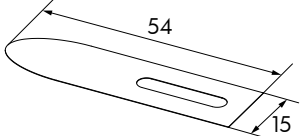
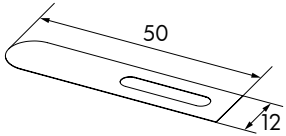
SHEET SEPARATOR 45x15		SHEET SEPARATOR 54x15		SHEET SEPARATOR 50x12	
SEPARAFOGLIO 45x15		SEPARAFOGLIO 54x15		SEPARAFOGLIO 50x12	
					
4210	0,10 mm - 100 pcs/pz	4410	0,10 mm - 100 pcs/pz	4510	0,10 mm - 100 pcs/pz
4220	0,20 mm - 100 pcs/pz	4420	0,20 mm - 100 pcs/pz	4520	0,20 mm - 100 pcs/pz
4230	0,30 mm - 100 pcs/pz	4430	0,30 mm - 100 pcs/pz	4530	0,30 mm - 100 pcs/pz

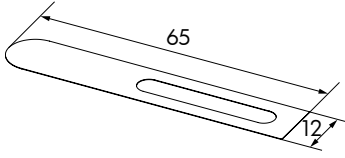
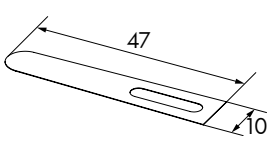
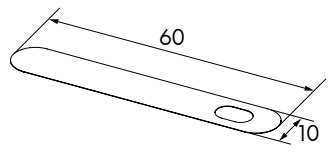
SHEET SEPARATOR 65x12		SHEET SEPARATOR 47x10		SHEET SEPARATOR 60x10	
SEPARAFOGLIO 65x12		SEPARAFOGLIO 47x10		SEPARAFOGLIO 60x10	
					
4610	0,10 mm - 100 pcs/pz	4710	0,10 mm - 100 pcs/pz	4740	0,10 mm - 100 pcs/pz
4620	0,20 mm - 100 pcs/pz	4720	0,20 mm - 100 pcs/pz	4745	0,20 mm - 100 pcs/pz
4630	0,30 mm - 100 pcs/pz	4730	0,30 mm - 100 pcs/pz	4750	0,30 mm - 100 pcs/pz

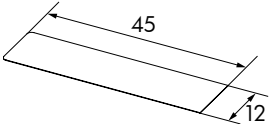
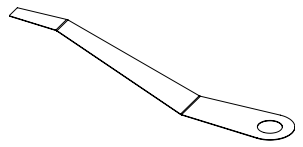
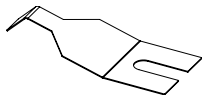
SHEET SEPARATOR 45x12		SHEET SEPARATOR 65x10		SHEET SEPARATOR FOR RYOBI	
SEPARAFOGLIO 45x12		SEPARAFOGLIO 65x10		SEPARAFOGLIO RYOBI	
					
4810	0,10 mm - 100 pcs/pz	4760	0,10 mm - 100 pcs/pz	4209	0,15 mm - 10 pieces
4820	0,20 mm - 100 pcs/pz	4765	0,20 mm - 100 pcs/pz		0,15 mm - 10 pezzi
4830	0,30 mm - 100 pcs/pz	4770	0,30 mm - 100 pcs/pz		

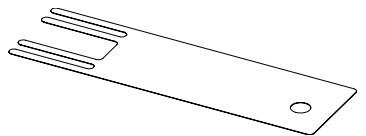
SHEET SEPARATOR FOR HORIZON	
SEPARAFOGLIO HORIZON	
	
9630	0,10 mm - 2 pieces 0,10 mm - 2 pezzi

SPARE PARTS FOR FEEDER

PARTI PER METTIFOGLIO

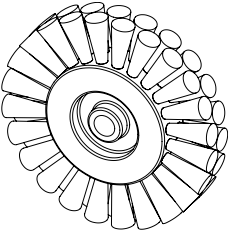
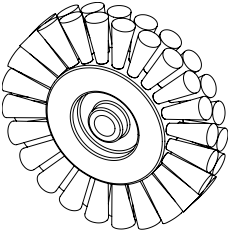
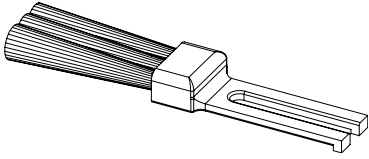
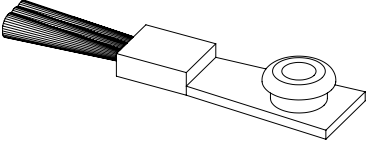
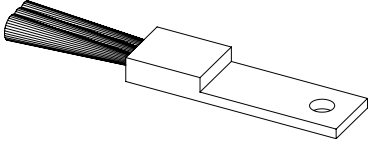
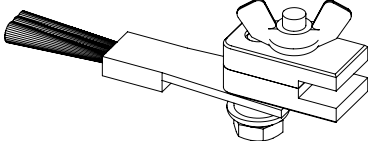
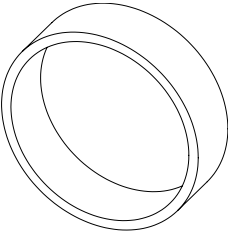
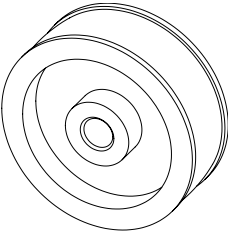
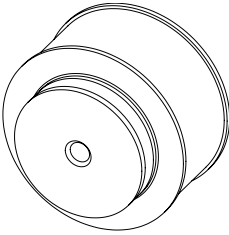
WHITE BRUSH WHEEL (soft - paper)		BLACK BRUSH WHEEL (hard - cardboard)		SHEET SEPARATING BRUSH - WHITE	
SPAZZOLA TONDA MORBIDA BIANCA		SPAZZOLA TONDA DURA NERA		SPAZZOLINA SEPARAFOGLI BIANCA	
					
9610	box 10 - each piece conf. 10 pz - ogni pezzo	9612	box 10 - each piece conf. 10 pz - ogni pezzo	9600	box 10 - each piece conf. 10 pz - ogni pezzo
SHEET SEPARATING BRUSH - BLACK		SHEET SEPARATING BRUSH - BLACK		BRUSH FOR GTO WITH CLAMP	
SPAZZOLINA SEPARAFOGLI BLACK		SPAZZOLINA SEPARAFOGLI BLACK		SPAZZOLINA PER GTO CON MORSETTO	
					
9602	box 10 - each piece conf. 10 pz - ogni pezzo	9608	box 10 - each piece conf. 10 pz - ogni pezzo	9551	each piece ogni pezzo
RUBBER RINGS FOR MABEG		ROLL FOR MABEG - 40x14 mm		ROLL FOR MABEG	
ANELLI IN GOMMA PER MABEG		ROTELLA PER MABEG - 40x14 mm		ROTELLA PER MABEG	
					
9537	∅ 38 x 12 mm	9629	HOLE / FORO ∅ 6 mm	9539	∅ 54 x 27 x ∅ 6 mm each piece - ogni pezzo
9538	∅ 50 x 25 mm	9632	HOLE / FORO ∅ 10 mm		

OTHER SPARE PARTS

ALTRE PARTI DI RICAMBIO

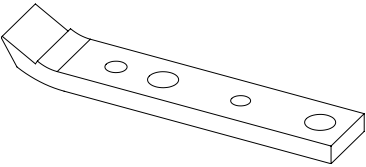
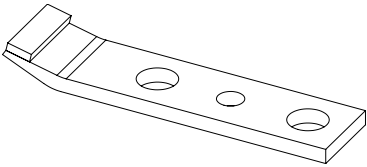
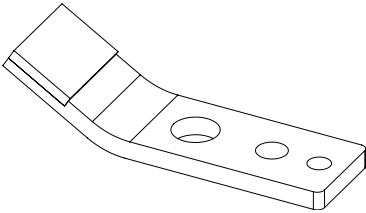
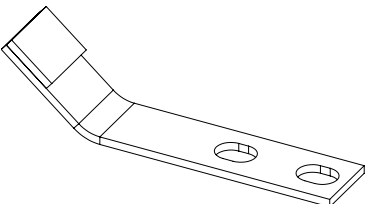
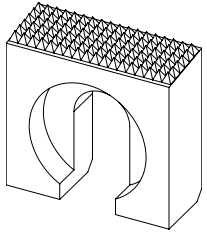
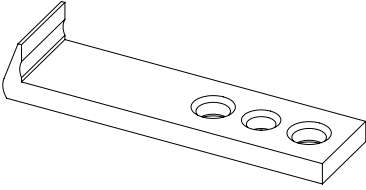
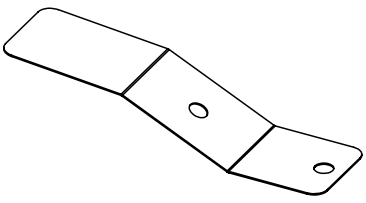
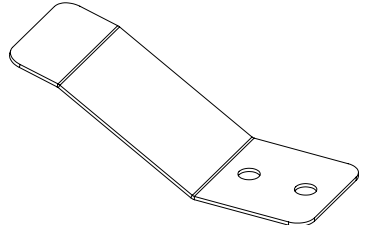
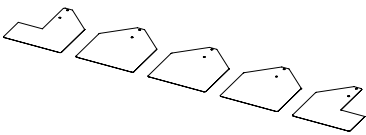
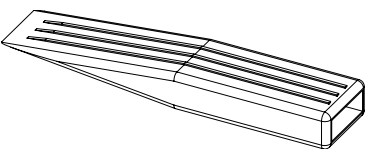
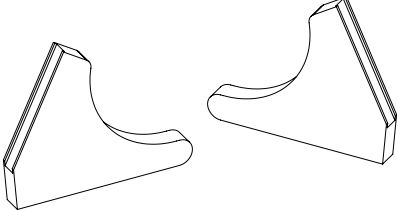
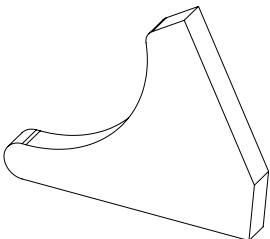
SPEEDMASTER CYLINDER GRIPPER		CYLINDER GRIPPER HEIDELBERG TYPO		DELIVERY GRIPPER MO	
PINZA CILINDRO SPEEDMASTER		PINZA CILINDRO TIPOGRAFICHE HBG		PINZA USCITA MO	
					
9528	box 10 - each piece conf. 10 pz - ogni pezzo	9525	box 10 - each piece conf. 10 pz - ogni pezzo	9586	box 10 - each piece conf. 10 pz - ogni pezzo
FEEDER GRIPPER HEIDELBERG		SPEEDMASTER GRIPPER PAD		SPEEDMASTER GRIPPER FINGER	
PINZA METTIFOGLIO HEIDELBERG		BLOCCHETTO CILINDRO SPEEDMASTER		PINZA CILINDRO SPEEDMASTER	
					
9519	box 2 - each piece conf. 2 pz - ogni pezzo	9626	each piece ogni pezzo	9628	each piece ogni pezzo
SHEET SMOOTHER KORD 64		SHEET SMOOTHER SPEEDMASTER		HEIDELBERG SHEET SMOOTHER	
LAMELLA GUIDAFOGLI KORD 64		LAMELLA GUIDAFOGLI SPEEDMASTER		LAMELLE GUIDAFOGLI HEIDELBERG	
					
9620	box 10 - each piece conf. 10 pz - ogni pezzo	9621	box 10 - each piece conf. 10 pz - ogni pezzo	1012	kit 3 + 2 lateral kit 3 + 2 laterali
SILICONE SHEET STOP HBG TYPO		TEFLON SEALS FOR KOMPAC		FELT SEALS FOR KOMPAC	
FERMAFOGLI SILICONE TIPOGRAFICHE		SPALLETTE TEFLON PER KOMPAC		SPALLETTE IN FELTRO PER KOMPAC	
					
9616	box 10 - each piece conf. 10 pz - ogni pezzo	8003	KOMPAC II	8005	box 20 - each box conf. 10 pz - ogni confezione
		8006	KOMPAC III		
		8008	KOMPAC V		

PIN BARS

BARRETTE DI MONTAGGIO

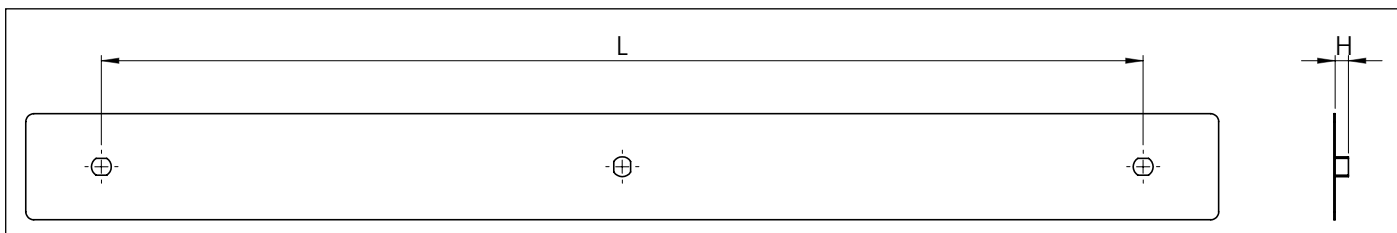

Ref Cod.	Lenght (L) Lunghezza (L)	Height (H) Altezza (H)	Pin Number Numero Pin	Pin Size Dim. Pin A x B		€
441982	198 mm	2 mm	2	5 x 6,5 + Ø 5 mm		
441985	198 mm	5 mm	2	5 x 6,5 + Ø 5 mm		
443932	393 mm	2 mm	3	6,35 x 7,5 mm		
443935	393 mm	5 mm	3	6,35 x 7,5 mm		
447482	748 mm	2 mm	3	6,35 x 7,5 mm		
447485	748 mm	5 mm	3	6,35 x 7,5 mm		
447487	393 + 748 mm	2 mm	5	6,35 x 7,5 mm		
447489	393 + 748 mm	5 mm	5	6,35 x 7,5 mm		
444002	400 mm	2 mm	3	5 x 6,5 mm		
444005	400 mm	5 mm	3	5 x 6,5 mm		
447552	755 mm	2 mm	3	5 x 6,5 mm		
447555	755 mm	5 mm	3	5 x 6,5 mm		
441172	1.175 mm	2 mm	3	5 x 6,5 mm		
441175	1.175 mm	5 mm	3	5 x 6,5 mm		

On request custom or combined pin bar configuration
 A richiesta barrette di montaggio combinate o personalizzate

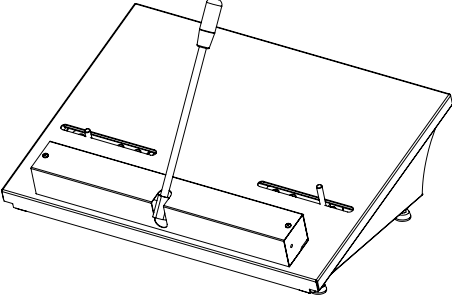
TABLE REGISTER PUNCHES PT 650 and PT 840		price starting from €
PUNZONATRICI DA TAVOLO PT 650 e PT 840		prezzi a partire da €
	<ul style="list-style-type: none"> • PT 650: FOR PLATES 35x50 (PLATES UP TO 650mm). • PT 840: FOR PLATES 50x70 (PLATES UP TO 840mm). • MANUAL OPERATION BY HANDLE 	
	<ul style="list-style-type: none"> • PT 650: PER LASTRE FORMATO 35x50 (FINO A 650 mm). • PT 840: PER LASTRE FORMATO 50x70 (FINO A 840 mm). • COMANDO MANUALE A LEVA 	

REGISTER PUNCHES PLP 920 - PLP 1200 - PLP 1820		price starting from €
PUNZONATRICI PLP 920 - PLP 1200 - PLP 1820		prezzi a partire da €
	<ul style="list-style-type: none"> • FOR PLATES 50x70 (PLP 920), 70x100 (PLP 1200) and 120x160 (PLP 1820). • MECHANICAL OPERATION VIA FOOT PEDAL OR PNEUMATIC VIA PUSH BUTTON. 	
	<ul style="list-style-type: none"> • PER LASTRE FORMATO 50x70 (PLP 920), 70x100 (PLP 1200) e 120x160 (PLP 1820). • COMANDO A PEDALE O PNEUMATICO A PULSANTE. 	

PLATE BENDER and PUNCH BENDERS		price starting from €
PIEGALASTRE E PIEGALASTRE-PUNZONATRICE		prezzi a partire da €
	<ul style="list-style-type: none"> • SUITABLE FOR HEIDELBERG and KOMORI 50x70 (BL 70 - BLC 70) and 70x100 (BL 100 - BLC 100) PRINTING MACHINES. • MANUAL OPERATION BY SINGLE HANDLE. 	
	<ul style="list-style-type: none"> • DISPONIBILE PER MACCHINE HEIDELBERG E KOMORI FORMATO 50x70 (BL 70 - BLC 70) E 70x100 (BL 100 - BLC 100). • COMANDO MANUALE A LEVA SINGOLA. 	

STANDARD PUNCHING CONFIGURATION

PUNZONATURE STANDARD

No. / Name N° / Cod.	Configuration Schema	Machine Macchina	PT 650	PT 840	PLP 920	PLP 1200	PLP 1820	BLC 70	BLC 100
1 220/11		HEIDELBERG RYOBI HAMADA	•	•	•	•	•	•	•
2 425/11+6,35		HEIDELBERG - RYOBI HAMADA - POLLY SAKURAI - AKIYAMA SHINOHARA	•	•	•	•	•	•	•
3 425/10+6,35		KBA	•	•	•	•	•	•	•
4 425/10+5		ROLAND	•	•	•	•	•	•	•
5 CtP 425/11		Up to / Fino a 50 x 70 CtP	•	•	•	•	•	•	•
6 CtP 425/10		Up to / Fino a 50 x 70 CtP	•	•	•	•	•	•	•
7 550/9+6,35		KOMORI		•	•	•	•	•	•
8 CtP 550/9		KOMORI with / con CtP		•	•	•	•	•	•
9 780/11+6,35		HEIDELBERG AKIYAMA SHINOHARA				•	•		•
10 CtP 780/11		Up to / Fino a 70 x 100 CtP				•	•		•
11 780/9+6,35		KBA				•	•		•

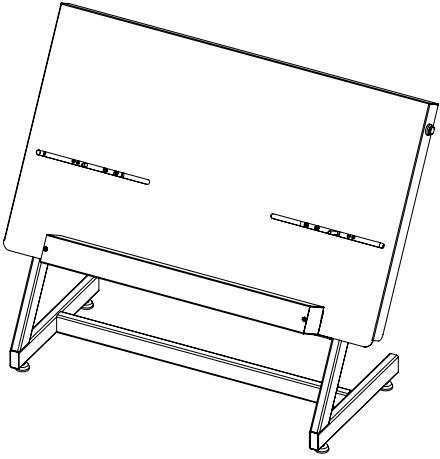
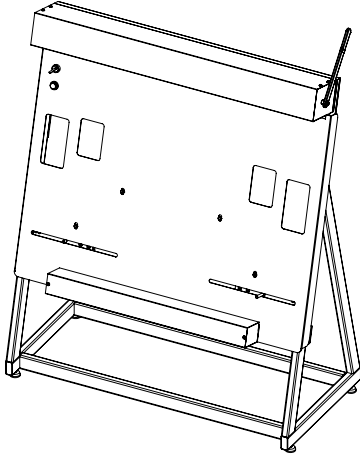
STANDARD PUNCHING CONFIGURATION



PUNZONATURE STANDARD



No. / Name N° / Cod.	Configuration Schema	Machine Macchina	PT 650	PT 840	PLP 920	PLP 1200	PLP 1820	BIC 70	BIC 100
12 780/10+5		ROLAND				●	●		●
13 CtP 780/10		Up to / Fino a 70 x 100 CtP				●	●		●
14 830/9+6,35		KOMORI				●	●		●
15 CtP 830/9		KOMORI with / con CtP				●	●		●
16 1168/9+6,35		KOMORI					●		
17 1200/9+6,35		KBA					●		
18 1200/10+5		ROLAND					●		



On request custom or combined punching configuration
A richiesta schemi di punzonatura combinati o personalizzati

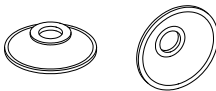

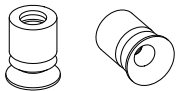
SHAPED RUBBER SUCKERS

VENTOSE SAGOMATE

Ref. / Cod.	Suitable for / per:	€	Ref. / Cod.	Suitable for / per:	€	Ref. / Cod.	Suitable for / per:	€
0126	HEIDELBERG / NEBIOLO		0128	HEIDELBERG		0130	HEIDELBERG / NEBIOLO	
								
est Ø	int Ø	thickness / spess.	est Ø	int Ø	thickness / spess.	est Ø	int Ø	thickness / spess.
18	7	7	19	7	3	27	7	6

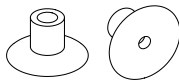
Ref. / Cod.	Suitable for / per:	€	Ref. / Cod.	Suitable for / per:	€	Ref. / Cod.	Suitable for / per:	€
0132	HEIDELBERG / ROLAND / KOMORI AURELIA / MILLER		0134	ALBERT / COLBUS / NEBIOLO		0136	-	
								
est Ø	int Ø	thickness / spess.	est Ø	int Ø	thickness / spess.	est Ø	int Ø	thickness / spess.
28	17	6	16	8	20	20	6	3

Ref. / Cod.	Suitable for / per:	€	Ref. / Cod.	Suitable for / per:	€	Ref. / Cod.	Suitable for / per:	€
0138	RYOBI		0141	-		0142	-	
								
est Ø	int Ø	thickness / spess.	est Ø	int Ø	thickness / spess.	est Ø	int Ø	thickness / spess.
18	3	4	22	8	6	24	6	13

Ref. / Cod.	Suitable for / per:	€	Ref. / Cod.	Suitable for / per:	€	Ref. / Cod.	Suitable for / per:	€
0144	HAMADA		0146	BREMER / SHERIDAN		0148	ROLAND / STAHL	
								
est Ø	int Ø	thickness / spess.	est Ø	int Ø	thickness / spess.	est Ø	int Ø	thickness / spess.
20	6	9	16	2	13	26	7	9



Box 50 pieces - price for each sucker



Scatole da 50 ventose - Prezzo per singola ventosa

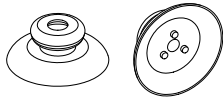
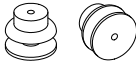
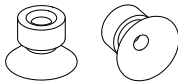

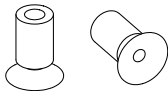
SHAPED RUBBER SUCKERS

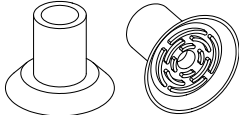
VENTOSE SAGOMATE

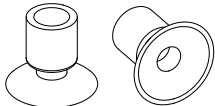
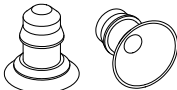
Ref. / Cod.	Suitable for / per:	€	Ref. / Cod.	Suitable for / per:	€	Ref. / Cod.	Suitable for / per:	€
0150	-		0152	PANDURO		0154	MÜLLER MARTINI	
								
est Ø	int Ø	thickness / spess.	est Ø	int Ø	thickness / spess.	est Ø	int Ø	thickness / spess.
30	5	12	15	2	12	21	6	15

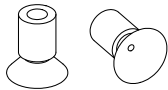

Ref. / Cod.	Suitable for / per:	€	Ref. / Cod.	Suitable for / per:	€	Ref. / Cod.	Suitable for / per:	€
0156	SHERIDAN / WOHEMBERG		0158	WINKLER		0160	ROLAND	
								
est Ø	int Ø	thickness / spess.	est Ø	int Ø	thickness / spess.	est Ø	int Ø	thickness / spess.
17	6	21	20	5	23	31	10	25

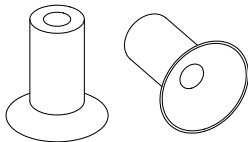

Ref. / Cod.	Suitable for / per:	€	Ref. / Cod.	Suitable for / per:	€	Ref. / Cod.	Suitable for / per:	€
0162	-		0164	RYOBI		0166	AURELIA / SHERIDAN	
								
est Ø	int Ø	thickness / spess.	est Ø	int Ø	thickness / spess.	est Ø	int Ø	thickness / spess.
27	10	23	22	6	22	26	5	20

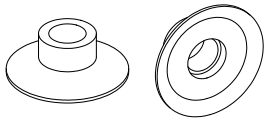

Ref. / Cod.	Suitable for / per:	€	Ref. / Cod.	Suitable for / per:	€	Ref. / Cod.	Suitable for / per:	€
0168	-		0170	-		0172	-	
								
est Ø	int Ø	thickness / spess.	est Ø	int Ø	thickness / spess.	est Ø	int Ø	thickness / spess.
18	8	20	17	12	15	30	8	33

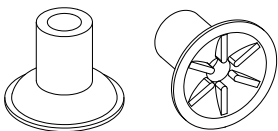

SHAPED RUBBER SUCKERS

VENTOSE SAGOMATE

Ref. / Cod.	Suitable for / per:	€	Ref. / Cod.	Suitable for / per:	€	Ref. / Cod.	Suitable for / per:	€
0174	-		0176	ROTAPRINT		0178	ROTAPRINT	
								
est Ø	int Ø	thickness / spess.	est Ø	int Ø	thickness / spess.	est Ø	int Ø	thickness / spess.
36	11	13	20	5	17	14	5	17

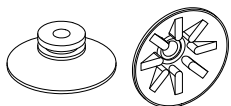
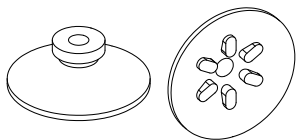

Ref. / Cod.	Suitable for / per:	€	Ref. / Cod.	Suitable for / per:	€	Ref. / Cod.	Suitable for / per:	€
0180	SIGMA		0182	MÜLLER MARTINI		0184	HAMADA	
								
est Ø	int Ø	thickness / spess.	est Ø	int Ø	thickness / spess.	est Ø	int Ø	thickness / spess.
35	10	27	16	7	10	18	6	6



Ref. / Cod.	Suitable for / per:	€	Ref. / Cod.	Suitable for / per:	€	Ref. / Cod.	Suitable for / per:	€
0186	FUJI - SHINOHARA		0188	HORIZONT		0190	BONELLI	
								
est Ø	int Ø	thickness / spess.	est Ø	int Ø	thickness / spess.	est Ø	int Ø	thickness / spess.
25	15	6	15	7	8	18	6	11

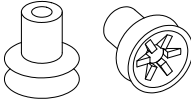
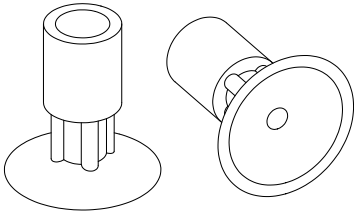

Ref. / Cod.	Suitable for / per:	€	Ref. / Cod.	Suitable for / per:	€	Ref. / Cod.	Suitable for / per:	€
0191	-		0192	MITSUBISHI		0194	ITALA	
								
est Ø	int Ø	thickness / spess.	est Ø	int Ø	thickness / spess.	est Ø	int Ø	thickness / spess.
32	5	10	43	8	15	15	7	12

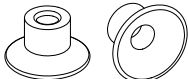

SHAPED RUBBER SUCKERS

VENTOSE SAGOMATE

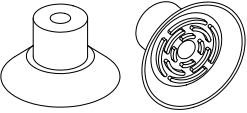
Ref. / Cod.	Suitable for / per:	€	Ref. / Cod.	Suitable for / per:	€	Ref. / Cod.	Suitable for / per:	€
0195	MULTILITH - TOKO		0196	CRABTREE - MAILANDER		0197	-	
								
est Ø	int Ø	thickness / spess.	est Ø	int Ø	thickness / spess.	est Ø	int Ø	thickness / spess.
22	6	23	46	16	50	27	8	8,5

Ref. / Cod.	Suitable for / per:	€	Ref. / Cod.	Suitable for / per:	€	Ref. / Cod.	Suitable for / per:	€
0198	SAKURAI		0200	MÜLLER MARTINI		0202	HORIZONT	
								
est Ø	int Ø	thickness / spess.	est Ø	int Ø	thickness / spess.	est Ø	int Ø	thickness / spess.
27,5	16	7	25	6	14	22	6	7,5



Ref. / Cod.	Suitable for / per:	€	Ref. / Cod.	Suitable for / per:	€	Ref. / Cod.	Suitable for / per:	€
0204	HORIZONT		0206	AURELIA		0208	RYOBI	
								
est Ø	int Ø	thickness / spess.	est Ø	int Ø	thickness / spess.	est Ø	int Ø	thickness / spess.
15,5	5	3	34	6,5	20	15	4,5	4



Ref. / Cod.	Suitable for / per:	€	Ref. / Cod.	Suitable for / per:	€	Ref. / Cod.	Suitable for / per:	€
0210	-		0212	STAHL		0214	NECKAR	
								
est Ø	int Ø	thickness / spess.	est Ø	int Ø	thickness / spess.	est Ø	int Ø	thickness / spess.
13	7	12	12	6	8,5	18	6	9,5

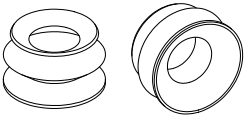
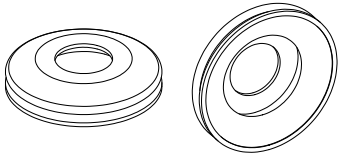

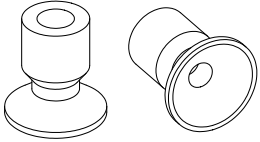
SHAPED RUBBER SUCKERS

VENTOSE SAGOMATE

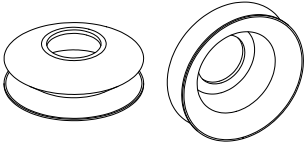
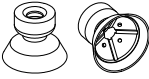
Ref. / Cod.	Suitable for / per:	€	Ref. / Cod.	Suitable for / per:	€	Ref. / Cod.	Suitable for / per:	€
0216	MÜLLER LACONDA		0218	ROLAND		0220	BOBST	
								
est Ø	int Ø	thickness / spess.	est Ø	int Ø	thickness / spess.	est Ø	int Ø	thickness / spess.
16	6,5	8,5	30,5	16	17,5	46	17	9,5



Ref. / Cod.	Suitable for / per:	€	Ref. / Cod.	Suitable for / per:	€	Ref. / Cod.	Suitable for / per:	€
0222	-		0226	-		0228	SHERIDAN	
								
est Ø	int Ø	thickness / spess.	est Ø	int Ø	thickness / spess.	est Ø	int Ø	thickness / spess.
15	5	16	12	5	14	17,5	3	18

Ref. / Cod.	Suitable for / per:	€	Ref. / Cod.	Suitable for / per:	€	Ref. / Cod.	Suitable for / per:	€
0230	BOBST		0232	-		0234	HEIDELBERG	
								
est Ø	int Ø	thickness / spess.	est Ø	int Ø	thickness / spess.	est Ø	int Ø	thickness / spess.
41	16	14	20	5	15	21	5	4

Ref. / Cod.	Suitable for / per:	€	Ref. / Cod.	Suitable for / per:	€	Ref. / Cod.	Suitable for / per:	€
0236	HEIDELBERG		0238	-		0239	-	
								
est Ø	int Ø	thickness / spess.	est Ø	int Ø	thickness / spess.	est Ø	int Ø	thickness / spess.
16	4	17	20	6	10	20	3,5	10

SHAPED RUBBER SUCKERS

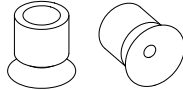
VENTOSE SAGOMATE

Ref. / Cod.	Suitable for / per:	€	Ref. / Cod.	Suitable for / per:	€	Ref. / Cod.	Suitable for / per:	€
0240	THISEN - BONITZ		0242	-		0243	HORAUF	
								
est Ø	int Ø	thickness / spess.	est Ø	int Ø	thickness / spess.	est Ø	int Ø	thickness / spess.
12/20	2	7	20	11	19	8	3	7,5

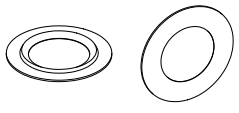
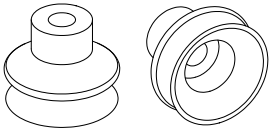
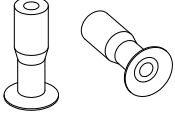
Ref. / Cod.	Suitable for / per:	€	Ref. / Cod.	Suitable for / per:	€	Ref. / Cod.	Suitable for / per:	€
0244	ROTAPRINT		0248	-		0249	HEIDELBERG	
								
est Ø	int Ø	thickness / spess.	est Ø	int Ø	thickness / spess.	est Ø	int Ø	thickness / spess.
32	17	1,5	30	8	27	15,5	5	31

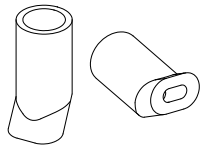
Ref. / Cod.	Suitable for / per:	€
0251	HAMADA	
		
est Ø	int Ø	thickness / spess.
12	8	35

FLAT RUBBER SUCKERS

VENTOSE PIATTE

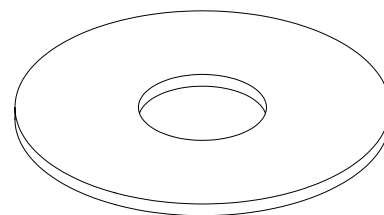
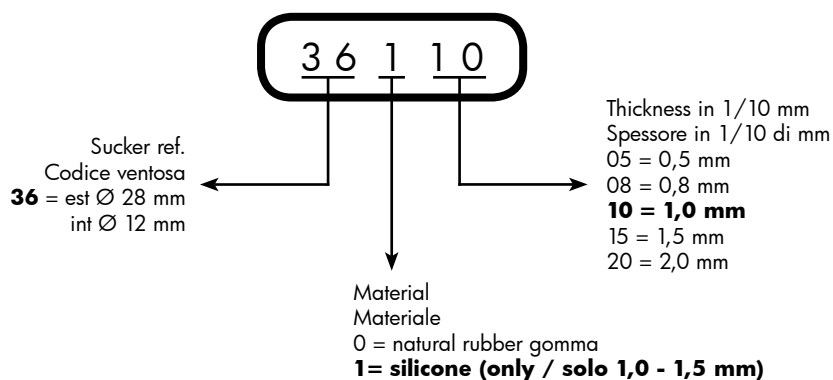

Box 50 pieces - price for each sucker
Buste 50 ventose - prezzo per singola ventosa

Ref. Cod.	External Ø x Internal Ø Ø Esterno x Ø Interno (mm)	€	
		Rubber Gomma	Silicone
01	10 x 2		
02	12 x 1		
03	13 x 2		
04	15 x 3		
05	16 x 2		
06	17 x 3		
07	19 x 2		
08	19 x 3		
09	19 x 5		
10	19 x 6		
11	19 x 7		
12	20 x 3		
13	20 x 5		
14	20 x 11		
15	21 x 5		
16	21 x 8		
17	22 x 3		
18	22 x 5		
19	22 x 6		
20	22 x 8		
21	22 x 9		
22	24 x 5		
23	24 x 6		
24	24 x 9		
25	24 x 12		
26	25 x 5		
27	25 x 6		
28	25 x 9		
29	27 x 3		
30	27 x 5		

Ref. Cod.	External Ø x Internal Ø Ø Esterno x Ø Interno (mm)	€	
		Rubber Gomma	Silicone
31	27 x 6		
32	27 x 9		
33	28 x 6		
34	28 x 7		
35	28 x 9		
36	28 x 12		
37	29 x 11		
38	29 x 12		
39	29 x 14		
40	30 x 5		
41	30 x 9		
42	30 x 11		
43	30 x 12		
44	30 x 13		
45	30 x 14		
46	32 x 5		
47	32 x 6		
48	32 x 9		
49	32 x 10		
50	32 x 11		
51	32 x 12		
52	32 x 13		
53	32 x 14		
54	32 x 15		
55	32 x 16		
56	33 x 15		
57	35 x 5		
58	35 x 6		
59	35 x 9		
60	35 x 10		

Ref. Cod.	External Ø x Internal Ø Ø Esterno x Ø Interno (mm)	€	
		Rubber Gomma	Silicone
61	35 x 12		
62	35 x 13		
63	35 x 14		
64	35 x 15		
65	36 x 15		
66	38 x 5		
67	38 x 9		
68	38 x 10		
69	38 x 11		
70	38 x 12		
71	38 x 13		
72	38 x 14		
73	38 x 15		
74	39 x 15		
75	40 x 9		
76	41 x 9		
77	41 x 12		
78	41 x 14		
79	41 x 16		
80	44 x 8		
81	45 x 13		
82	45 x 14		
83	45 x 15		
84	45 x 16		
85	45 x 17		
86	50 x 6		
87	50 x 8		
88	50 x 13		
89	50 x 14		

QUOINS

SERRAFORME

Ref. Codice	Model Tipo	Measure Misura	€
6242	KEY FOR QUOINS Rg. 2,5 CHIAVE PER SERRAFORME 2,5 Rg	Rg 2,5 - \varnothing 4 mm	
6238	REPLACEMENT PART FOR QUOINS MECCANISMO DI RICAMBIO	Rg 2,5	
6245	QUOIN SERRAFORMA	Rg 2,5 x 5 cm	
6246	QUOIN SERRAFORMA	Rg 2,5 x 7,5 cm	
6247	QUOIN SERRAFORMA	Rg 2,5 x 10 cm	
6248	QUOIN SERRAFORMA	Rg 2,5 x 15 cm	
6249	QUOIN SERRAFORMA	Rg 2,5 x 15 cm dt	
6250	QUOIN SERRAFORMA	Rg 2,5 x 20 cm dt	
6251	QUOIN SERRAFORMA	Rg 2,5 x 25 cm dt	
6252	QUOIN SERRAFORMA	Rg 2,5 x 30 cm dt	
6243	KEY FOR QUOINS Rg. 4 CHIAVE PER SERRAFORME 4 Rg	Rg 4 - \varnothing 6 mm	
6239	REPLACEMENT PART FOR QUOINS MECCANISMO DI RICAMBIO	Rg 4	
6260	QUOIN SERRAFORMA	Rg 4 x 5 cm	
6261	QUOIN SERRAFORMA	Rg 4 x 7,5 cm	
6262	QUOIN SERRAFORMA	Rg 4 x 10 cm	
6263	QUOIN SERRAFORMA	Rg 4 x 15 cm	
6264	QUOIN SERRAFORMA	Rg 4 x 15 cm dt	
6265	QUOIN SERRAFORMA	Rg 4 x 20 cm dt	
6266	QUOIN SERRAFORMA	Rg 4 x 25 cm dt	
6267	QUOIN SERRAFORMA	Rg 4 x 30 cm dt	
6244	KEY FOR SAMSON QUOINS CHIAVE PER SERRAFORME SAMSON		
6338	SAMSON QUOIN SERRAFORMA SAMSON	N° 2 - 7,5 cm	
6339	SAMSON QUOIN SERRAFORMA SAMSON	N° 3 - 11 cm	
6340	SAMSON QUOIN SERRAFORMA SAMSON	N° 4 - 15 cm	
6342	SAMSON QUOIN SERRAFORMA SAMSON	N° 5 - 19 cm	
6344	SAMSON QUOIN SERRAFORMA SAMSON	N° 6 - 22 cm	
6346	SAMSON QUOIN SERRAFORMA SAMSON	N° 7 - 26 cm	
6348	SAMSON QUOIN SERRAFORMA SAMSON	N° 8 - 30 cm	

PLASTIC JOGGER BLOCKS

SPINGI-CARTA IN PLASTICA

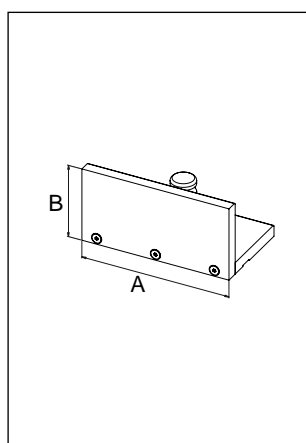

Ref. Codice	Size (A x B) Dimensioni (A x B)	€	Ref. Codice	Size Dimensioni	€
3450	200 x 75 mm		3457	400 x 125 mm	
3451	250 x 75 mm		3458	450 x 125 mm	
3452	200 x 100 mm		3459	300 x 150 mm	
3453	250 x 100 mm		3460	400 x 150 mm	
3454	300 x 100 mm		3461	450 x 150 mm	
3455	250 x 125 mm		3462	650 x 150 mm	
3456	300 x 125 mm				

CHANNEL

STANDARD

STEEL BASE 9 mm - 750 mm LONG. / BASE IN ACCIAIO da 9 mm - PEZZI DA 750 mm

Ref. Codice	Color Colore	Dept Profondità	Width Larghezza	Grams Grammi	µm	Meters Metri	€
7170	GOLD ORO	0,38 mm	0,56 mm	50/150	> 150	24	
7172	ORANGE ARANCIO	0,32 mm	0,80 mm	100/150	> 150	24	
7174	BUFF CAMOSCIO	0,38 mm	1,00 mm	150/200	> 250	24	
7176	WHITE BIANCO	0,43 mm	1,30 mm	200/275	200 - 400	24	
7178	YELLOW GIALLO	0,48 mm	1,50 mm	275/335	350 - 500	24	
7180	MAUVE MALVA	0,53 mm	1,70 mm	335/400	450 - 600	24	
7182	GREEN VERDE	0,58 mm	1,90 mm	400/465	500 - 700	24	
7184	MAROON MATTONE	0,63 mm	2,10 mm	465/535	650 - 800	24	
7186	RED ROSSO	0,68 mm	2,30 mm	535/600	750 - 900	24	
7188	BLUE BLU	0,79 mm	2,70 mm	600/665	850 - 1.000	24	
7190	BROWN MARRONE	1,00 mm	3,00 mm	665/750	950 - 1.200	12	

CHANNEL

OFF CENTRE (2 mm) / LATERALE (2 mm)

STEEL BASE 9 mm - 750 mm LONG. / BASE IN ACCIAIO da 9 mm - PEZZI DA 750 mm

Ref. Codice	Color Colore	Dept Profondità	Width Larghezza	Grams Grammi	µm	Meters Metri	€
7200	BUFF CAMOSCIO	0,38 mm	1,00 mm	150/200	> 250	24	
7202	WHITE BIANCO	0,43 mm	1,30 mm	200/275	200 - 400	24	
7204	YELLOW GIALLO	0,48 mm	1,50 mm	275/335	350 - 500	24	

CHANNEL

DOUBLE (3 mm) / DOPPIO (3 mm)

STEEL BASE 9 mm - 750 mm LONG. / BASE IN ACCIAIO da 9 mm - PEZZI DA 750 mm

Ref. Codice	Color Colore	Dept Profondità	Width Larghezza	Grams Grammi	µm	Meters Metri	€
7212	WHITE BIANCO	0,43 mm	1,30 mm	200/275	200 - 400	12	

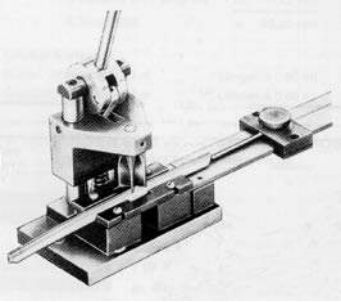
Ref. Codice	7266
	
CUTTING PRESS FOR MATRIX PRESSA TAGLIA CANALETTO	
€	

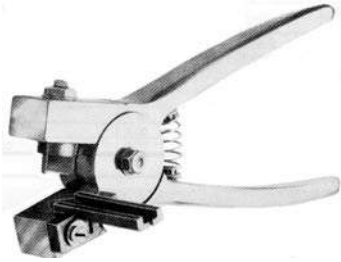
Ref. Codice	7268
	
CUTTING GRIPPER FOR MATRIX PINZA TAGLIA CANALETTO	
€	

**SKILL
STANDARD**

PVC BASE 12 mm - 750 mm LONG. / BASE IN PVC da 12 mm - PEZZI DA 750 mm

Ref. Codice	Color Colore	N°	Dept Profondità	Width Larghezza	Grams Grammi	µm	Meters Metri	€
7302	PINK ROSA	N. 0	0,3 mm	0,80 mm	100/150	> 150	18	
7304	GREY GRIGIO	N. 1	0,4 mm	1,00 mm	150/200	150 - 250	18	
7306	WHITE BIANCO	N. 2	0,5 mm	1,30 mm	200/275	200 - 400	18	
7308	DARK BLUE BLU	N. 3	0,5 mm	1,50 mm	275/335	350 - 500	18	
7310	YELLOW GIALLO	N. 4	0,6 mm	1,70 mm	335/400	450 - 650	18	
7312	GREEN VERDE	N. 5	0,6 mm	1,90 mm	400/465	575 - 775	18	
7314	BROWN MARRONE	N. 6	0,8 mm	2,30 mm	465/600	750 - 900	18	
7316	LIGHT BLUE AZZURRO	N. 7	0,8 mm	2,50 mm	600/750	875 - 1.200	18	
7318	RED ROSSO	N. 8	1,0 mm	3,00 mm	solid board	-	18	
7320	VIOLET VIOLA	N. 8a	1,0 mm	3,50 mm	solid board	-	18	
7322	BLACK NERO	N. 9	1,0 mm	4,00 mm	heavy solid board	-	18	
7324	GOLD ORO	N. 10	1,0 mm	5,00 mm	heavy solid board	-	18	

**XTC
STANDARD**

PVC BASE 9 mm - 750 mm LONG. / BASE IN PVC da 9 mm - PEZZI DA 750 mm

Ref. Codice	Color Colore	Use with Uso	Dept Profondità	Width Larghezza	Grams Grammi	µm	Meters Metri	€
7402	PINK ROSA	Cardboard	0,3 mm	0,80 mm	100/150	> 150	24	
7404	GREY GRIGIO	Cardboard	0,4 mm	1,00 mm	150/200	150 - 250	24	
7406	WHITE BIANCO	Cardboard	0,5 mm	1,30 mm	200/275	200 - 400	24	
7408	BLUE BLU	Cardboard	0,5 mm	1,50 mm	275/335	350 - 500	24	
7410	YELLOW GIALLO	Cardboard	0,6 mm	1,70 mm	335/400	450 - 650	24	
7412	GREEN VERDE	Cardboard	0,6 mm	1,90 mm	400/465	575 - 775	24	
7414	BROWN MARRONE	Cardboard	0,8 mm	2,30 mm	465/600	750 - 900	24	
7416	LIGHT BLUE AZZURRO	Cardboard microwaves	0,8 mm	2,50 mm	600/750	875 - 1.200	24	





**XTC
OFF CENTRE / LATERALE**

PVC BASE 9 mm - 750 mm LONG. / BASE IN PVC da 9 mm - PEZZI DA 750 mm

Ref. Codice	Color Colore	Use with Uso	Dept Profondità	Width Larghezza	Grams Grammi	µm	Meters Metri	€
7420	GREY GRIGIO	Cardboard	0,4 mm	1,00 mm	150/200	150 - 250	24	
7422	WHITE BIANCO	Cardboard	0,5 mm	1,30 mm	200/275	200 - 400	24	
7424	BLUE BLU	Cardboard	0,5 mm	1,50 mm	275/335	350 - 500	24	

CUTTING / CREASING RULES

FILETTI

Ref. Codice	Color Colore		Pt	Height Altezza	Thickness Spessore	€	
7031	CREASING CENTRAL	CORDONATORE CENTRALE		2	22,8 mm	0,71 mm	
7032	CUTTING CENTRAL	TAGLIO CENTRALE		2	23,5 mm	0,71 mm	
7046	CUTTING CENTRAL	TAGLIO CENTRALE		2	23,8 mm	0,71 mm	
7047	CUTTING OFF CENTRE	TAGLIO LATERALE		2	23,8 mm	0,71 mm	
7050	PERFORATING 1x1	PERFORATORE 1x1	-----	2	23,5 mm	0,71 mm	
7051	PERFORATING 2x1	PERFORATORE 2x1	-----	2	23,5 mm	0,71 mm	

Ref. Codice	Model Descrizione	€
7108	BRASS COUNTER DRILLERS - ROLL 4 mm x 25 m	
	CONTROFORATORI IN OTTONE - BOBINA 4 mm x 5 m	
7090	BI-ADHESIVE FOR COUNTER DRILLER - 5 ROLL 4 mm x 25 m	
	BIADESIVO PER CONTROFORATORE - 5 BOBINE 4 mm x 25 m	
7262	SELF ADHESIVE STEEL 0,025 mm - ROLL 10 m	
	ACCIAIO AUTOADESIVO PER TACCHEGGIO 0,025 mm - BOBINA 10 m	
7264	SELF ADHESIVE STEEL 0,050 mm - ROLL 10 m	
	ACCIAIO AUTOADESIVO PER TACCHEGGIO 0,050 mm - BOBINA 10 m	

OFFSET RULES

NASTRI PERFORATORI OFFSET

Ref. Codice	Color Colore		Use with Adatto per	Cuts per inch Tagli x pollice	Box	€
3102	OFFSET-PERF-CENTER	— — — — —	PAPER / CARTA 60-200 g	3 Zahne/"	6 m	
3104	OFFSET-PERF-CENTER	-----	PAPER / CARTA 60-200 g	6 Zahne/"	6 m	
3106	OFFSET-PERF-CENTER	-----	PAPER / CARTA 60-200 g	8 Zahne/"	6 m	
3108	OFFSET-PERF-CENTER	-----	PAPER / CARTA 60-200 g	12 Zahne/"	6 m	
3110	OFFSET-PERF-CENTER	-----	PAPER / CARTA 60-200 g	16 Zahne/"	6 m	
3111	OFFSET-PERF-SIDE	-----	PAPER / CARTA 60-200 g	8 Zahne/"	6 m	
3112	OFFSET-SCHNEID-CENTER	—————	PAPER / CARTA 60-200 g	CUT/TAGLIO	6 m	
3114	OFFSET-RILL-CENTER	—————	PAPER / CARTA 60-200 g	CREASING CORDONATURA	6 m	
3116	OFFSET-PERF-CENTER	— — — — —	CARDBOARD / CARTONE 200-300 g	3 Zahne/"	6 m	
3118	OFFSET-PERF-CENTER	-----	CARDBOARD / CARTONE 200-300 g	6 Zahne/"	6 m	
3120	OFFSET-PERF-CENTER	-----	CARDBOARD / CARTONE 200-300 g	8 Zahne/"	6 m	
3122	OFFSET-PERF-CENTER	-----	CARDBOARD / CARTONE 200-300 g	12 Zahne/"	6 m	
3124	OFFSET-PERF-CENTER	-----	CARDBOARD / CARTONE 200-300 g	16 Zahne/"	6 m	
3125	OFFSET-PERF-SIDE	-----	CARDBOARD / CARTONE 200-300 g	8 Zahne/"	6 m	
3126	OFFSET-SCHNEID-CENTER	—————	CARDBOARD / CARTONE 200-300 g	CUT/TAGLIO	6 m	
3128	OFFSET-RILL-CENTER	—————	CARDBOARD / CARTONE 200-300 g	CREASING CORDONATURA	6 m	

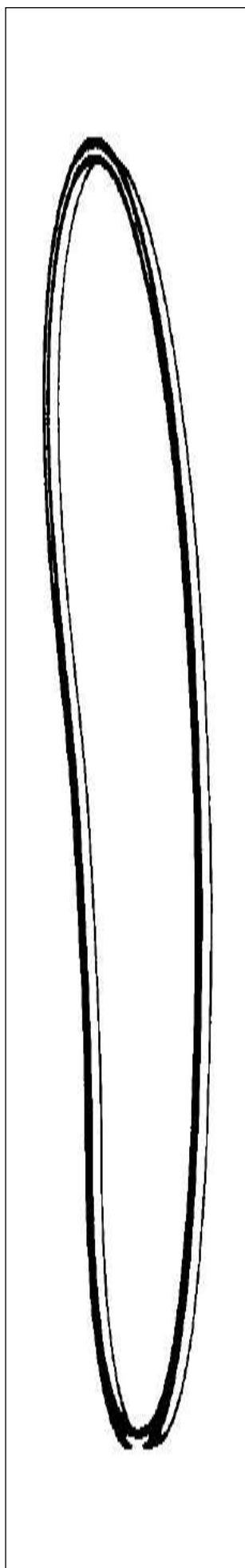

Ref. Codice	Belt N. Cod. Cinghia	Model Descrizione	L (mm)	€
9005	47J2320	HEIDELBERG PLATEN T 26x38 - old model - up to serial n. 160.000 HEIDELBERG STELLA T 26x38 - mod. vecchio - fino matr. 160.000	2.320	
9010	47J2290	HEIDELBERG PLATEN T 26x38 - new model - over serial n. 160.000 HEIDELBERG STELLA T 26x38 - mod. nuovo - oltre matr. 160.000	2.290	
9015	47J2880	HEIDELBERG PLATEN GT 32x46 HEIDELBERG STELLA GT 32x46	2.880	
9020	47J1820	HEIDELBERG KS / KSB / KSBA HEIDELBERG KS / KSB / KSBA	1.820	
9022	47J1880	HEIDELBERG KOR / KORA / KORD / KORS HEIDELBERG KOR / KORA / KORD / KORS	1.880	
9025	47J1580	HEIDELBERG SORM HEIDELBERG SORM	1.580	
9030	1168J10	FLYWHEEL HEIDELBERG GTO 46 MONOCOLOR VOLANO HEIDELBERG GTO 46 MONOCOLORE	1.168	
9031	1397J24	FLYWHEEL HEIDELBERG GTO 46/52 - 2 & 4 COLORS VOLANO HEIDELBERG GTO 46/52 - 2 e 4 COLORI	1.397	
9032	1321J16	FLYWHEEL HEIDELBERG GTO 52 MONOCOLOR VOLANO HEIDELBERG GTO 52 MONOCOLORE	1.321	
9035	27H0955	VARIOMATIC HEIDELBERG GTO 46/52 VARIATORE HEIDELBERG GTO 46/52	955	
9036	1550J24	SHEET FEEDER HEIDELBERG GTO ZS METTIFOGLIO HEIDELBERG GTO ZS	1.550	
9037	37J1060	VARIOMATIC HEIDELBERG GTO 46/52 BICOLOR VARIATORE HEIDELBERG GTO 46/52 BICOLORE	1.060	
9033	-	HEIDELBERG GTO 46/52 - ANTI SET-OFF POWDER HEIDELBERG GTO 46/52 - ANTISCARTINO	460	
9038	2134L19	HEIDELBERG SPEEDMASTER HEIDELBERG SPEEDMASTER	2.134	
9040	47J2480	GRAFOPRESS GPA / GPC / GPE GRAFOPRESS GPA / GPC / GPE	2.480	
9039	1473J580	HEIDELBERG MO HEIDELBERG MO	1.473	

NAGEL

BOX OF 5.000 STAPLES / SCATOLINE DA 5.000 PUNTI

Ref. Codice	Model Tipo	Measure Misura	€
8806	STEEL STAPLES	PUNTI METALLICI	50/6
8808	STEEL STAPLES	PUNTI METALLICI	50/8
8810	HARDENED STEEL STAPLES	PUNTI METALLICI	50/10 S
8812	HARDENED STEEL STAPLES	PUNTI METALLICI	50/12 S
8815	HARDENED STEEL STAPLES	PUNTI METALLICI	50/15 S
8818	HARDENED STEEL STAPLES	PUNTI METALLICI	50/18 S
8820	HARDENED STEEL STAPLES	PUNTI METALLICI	50/20 S
8826	STEEL STAPLES	PUNTI METALLICI	26/6 - RAPID 66/6
8828	HARDENED STEEL STAPLES	PUNTI METALLICI	26/8 S - RAPID 66/8
8829	LOOP STEEL STAPLES	PUNTI METALLICI con Ω	Ri 26/6 - RAPID 66 RING
8836	STEEL STAPLES	PUNTI METALLICI	24/6 - RAPID 44/6
8838	STEEL STAPLES	PUNTI METALLICI	24/8 - RAPID 44/8
8840	HARDENED STEEL STAPLES	PUNTI METALLICI	24/10 S
8843	HARDENED STEEL STAPLES	PUNTI METALLICI	24/13 S
8845	HARDENED STEEL STAPLES	PUNTI METALLICI	24/15 S
8848	HARDENED STEEL STAPLES	PUNTI METALLICI	24/18 S
8850	LOOP STEEL STAPLES	PUNTI METALLICI con Ω	Ri 24/6
8852	LOOP STEEL STAPLES	PUNTI METALLICI con Ω	Ri 24/8

STITCHING WIRE

FILO METALLICO

Ref. Codice	Model Tipo	N°	Size Dimensioni	Roll Bobina	€
8300	ZINC COATED FLAT HARDENED METALLIC STITCHING WIRE FILO METALLICO ACCIAIOSO PIATTO ZINCATO	5 C	0,90 x 0,65 mm	2 Kg	
8302	ZINC COATED FLAT METALLIC STITCHING WIRE FILO METALLICO PIATTO ZINCATO	5	0,90 x 0,65 mm	2 Kg	
8304	ZINC COATED FLAT METALLIC STITCHING WIRE FILO METALLICO PIATTO ZINCATO	2	0,75 x 0,40 mm	2 Kg	
8306	ZINC COATED ROUND METALLIC STITCHING WIRE FILO METALLICO TONDO ZINCATO	21	Ø 0,90 mm	2 Kg	
8308	ZINC COATED ROUND METALLIC STITCHING WIRE FILO METALLICO TONDO ZINCATO	23	Ø 0,70 mm	2 Kg	
8310	ZINC COATED ROUND METALLIC STITCHING WIRE FILO METALLICO TONDO ZINCATO	24	Ø 0,60 mm	2 Kg	
8314	ZINC COATED ROUND METALLIC STITCHING WIRE FILO METALLICO TONDO ZINCATO	25	Ø 0,55 mm	2 Kg	
8318	ZINC COATED ROUND METALLIC STITCHING WIRE FILO METALLICO TONDO ZINCATO	26	Ø 0,50 mm	2 Kg	

SMALL PUNCHES

FUSTELLINE

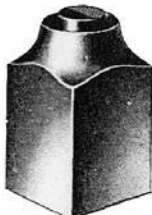
	Ref. Codice	Model Descrizione	Body Corpo	€
	7003	Ø 3 mm	20	
	7004	Ø 4 mm	20	
	7005	Ø 5 mm	20	
	7006	Ø 6 mm	20	
	7007	Ø 7 mm	20	
	7008	Ø 8 mm	30	
	7009	Ø 9 mm	30	
7010	Ø 10 mm	30		

METALLIC EYELETS

OCCHIELLI IN METALLO

Ref. Codice	Model Tipo	Measure Misura	€
8078	SMALL METALLIC EYELETS - BOX 10.000 PIECES - PRICE EACH BOX OCCHIELLI METALLICI PICCOLI - CONF. DA 10.000 PZ - PREZZO PER CONFEZIONE	H: 4 mm - Ø int. 4 mm	
8080	BIG METALLIC EYELETS - BOX 2.500 PIECES - PRICE EACH BOX OCCHIELLI METALLICI GRANDI - CONF. DA 2.500 PZ - PREZZO PER CONFEZIONE	H: 6 mm - Ø int. 6 mm	

THERMOGRAPHIC POWDER

POLVERE PER RILIEVO

Ref. Codice	Color Colore	Type Tipo	Weight Peso	€
6036	n° 2 HI-FLO CLEAR CP 24-60 TRASPARENTE	MEDIUM / MEDIA	1 Kg	
6038	n° 3 HI-FLO CLEAR CP 14-24 TRASPARENTE	THIN / FINE	1 Kg	
6040	n° 4 HI-FLO CLEAR CP 12 TRASPARENTE	EXTRA THIN / EXTRA FINE	1 Kg	
6042	PORCELAIN WHITE BIANCO NEVE	THIN / FINE	1 Kg	
6043	PORCELAIN WHITE BIANCO NEVE	EXTRA THIN / EXTRA FINE	1 Kg	
6044	SILVER ARGENTO	THIN / FINE	1 Kg	
6046	GOLD ORO	THIN / FINE	1 Kg	

GLUE

COLLA

Ref. Codice	Type Tipo	Use Uso	Weight Peso	€
8700	PLANATOL FF	FOR BLOCKS / PER BLOCCHI	1 Kg	
8701	PLANATOL FF	FOR BLOCKS / PER BLOCCHI	5 Kg	
8716	PLANATOL BB SUPERIOR	FOR ART PAPER / PER CARTA PATINATA	1 Kg	
8717	PLANATOL BB SUPERIOR	FOR ART PAPER / PER CARTA PATINATA	5,5 Kg	
8733	FGG 98	FOR MASTICHING / PER MASTICIARE	2 Kg	
8734	FGG 98/EA	FOR PLASTIC / PER PLASTICA	2 Kg	
8735	FGG 86/AF SELF SEPARATING - AUTOSEPARANTE	FOR CHEMICAL PAPER / PER CARTA CHIMICA	1 Kg	

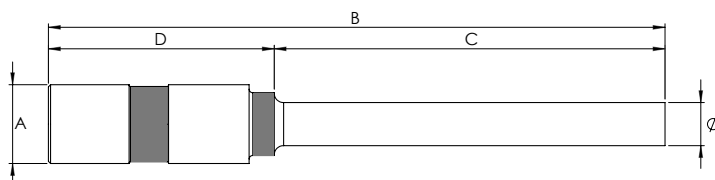

Ref. Codice	Ø mm	Ø Shaft (A) Ø Attacco (A)	Total lenght (mm) (B) Lunghezza totale (mm) (B)	Perforating lenght (mm) (C) Profondità foro (mm) (C)	Tang lenght (mm) (D) Lunghezza attacco (mm) (D)	€
6047	2,0	11	58	25	33	
6048	2,5	11	58	25	33	
6049	3,0	11	65	30	35	
6050	3,5	11	65	30	35	
6051	4,0	11	75	40	35	
6052	4,5	11	75	40	35	
6053	5,0	11	86	50	36	
6054	5,5	11	86	50	36	
6055	6,0	11	86	50	36	
6056	6,5	11	86	50	36	
6057	7,0	11	86	50	36	
6058	7,5	11	86	50	36	
6059	8,0	11	86	50	36	
6060	8,5	11	86	50	36	
6061	9,0	11	86	50	36	
6062	9,5	16	86	50	36	
6063	10,0	16	86	50	36	
6064	10,5	16	86	50	36	
6065	11,0	16	86	50	36	
6066	11,5	16	86	50	36	
6067	12,0	16	86	50	36	
6068	12,5	16	86	50	36	
6069	13,0	16	86	50	36	
6070	13,5	16	86	50	36	
6071	14,0	16	86	50	36	
6085	2,0	11	80	25	55	
6086	2,5	11	80	25	55	
6087	3,0	11	80	25	55	
6088	3,5	11	80	25	55	
6078	5,0	11	100	70	30	
6079	5,5	11	100	70	30	
6080	6,0	11	100	70	30	
6081	6,5	11	100	70	30	
6082	7,0	11	100	70	30	
6083	7,5	11	100	70	30	
6084	8,0	11	100	70	30	

PAPER DRILL BITS

PUNTE PER TRAPANI

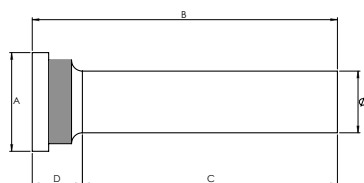



Ref. Codice	Ø mm	Ø Shaft (A) Ø Attacco (A)	Total lenght (mm) (B) Lunghezza totale (mm) (B)	Perforating lenght (mm) (C) Profondità foro (mm) (C)	Tang lenght (mm) (D) Lunghezza attacco (mm) (D)	€
6072	15,0	24	74	60	14	
6073	16,0	24	74	60	14	
6074	17,0	24	74	60	14	
6075	18,0	24	74	60	14	
6076	19,0	24	74	60	14	
6077	20,0	24	74	60	14	

TEFLON COATED PAPER DRILL BITS

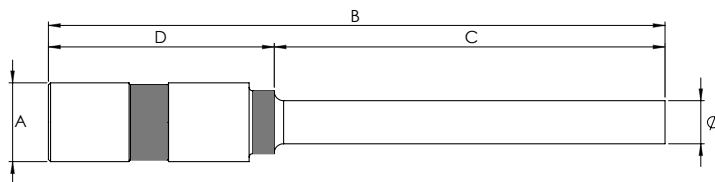
PUNTE PER TRAPANI TEFLONATE

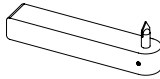

Ref. Codice	Ø mm	Ø Shaft (A) Ø Attacco (A)	Total lenght (mm) (B) Lunghezza totale (mm) (B)	Perforating lenght (mm) (C) Profondità foro (mm) (C)	Tang lenght (mm) (D) Lunghezza attacco (mm) (D)	€
6151	4,0	11	75	40	35	
6153	5,0	11	86	50	36	
6155	6,0	11	86	50	36	
6157	7,0	11	86	50	36	
6159	8,0	11	86	50	36	

6089	WAX PAPER CARTA PARAFFINATA				8 x 24 cm - H: 2,5 cm	
6091	SHARPENER FOR DRILLING MACHINE - ALL DIAMETERS AFFILATORE PER FUSTELLE - TUTTI I DIAMETRI					
6092	WIDIA SPARE PART FOR SHARPENER RICAMBIO WIDIA PER AFFILATORE PER FUSTELLE					
6095	SHARPENING STONE PIETRA ABRASIVA PER FUSTELLE				25 x 100 x 5 mm	

CUTTING STICKS

LISTELLI SOTTOLAMA

Ref. Codice	Machine Macchina	Color & type Colore e tipo	Measure Misura	€
8882	POLAR 72	RED WAVY / ROSSO ONDULATO	10 x 4,5 x 730	
8883	POLAR 76	RED WAVY / ROSSO ONDULATO	10 x 4,5 x 770	
8884	POLAR 80/82	RED WAVY / ROSSO ONDULATO	10 x 4,5 x 830	
8886	POLAR 92	RED WAVY / ROSSO ONDULATO	10 x 4,5 x 930	
8888	POLAR 105/107	RED WAVY / ROSSO ONDULATO	10 x 4,5 x 1.080	
8889	POLAR 115	RED WAVY / ROSSO ONDULATO	10 x 4,5 x 1.160	
8890	POLAR 132	RED WAVY / ROSSO ONDULATO	10 x 4,5 x 1.330	
8892	POLAR 145	RED WAVY / ROSSO ONDULATO	10 x 4,5 x 1.460	
8894	POLAR 155	RED WAVY / ROSSO ONDULATO	10 x 4,5 x 1.560	
8895	POLAR 171	RED WAVY / ROSSO ONDULATO	10 x 4,5 x 1.700	
8896	POLAR 80/82	GREY WAVY / GRIGIO ONDULATO	10 x 4,5 x 830	
8897	POLAR 92	GREY WAVY / GRIGIO ONDULATO	10 x 4,5 x 930	
8898	POLAR 105/107	GREY WAVY / GRIGIO ONDULATO	10 x 4,5 x 1.080	
8899	POLAR 115	GREY WAVY / GRIGIO ONDULATO	10 x 4,5 x 1.160	
8901	POLAR 155	GREY WAVY / GRIGIO ONDULATO	10 x 4,5 x 1.560	
8902	WOHLEMBERG	RED STRAIGHT / ROSSO DRITTO	18 x 4 x 878	
8904	WOHLEMBERG	RED STRAIGHT / ROSSO DRITTO	18 x 4 x 1.080	
8906	WOHLEMBERG	RED STRAIGHT / ROSSO DRITTO	18 x 4 x 1.335	
8908	WOHLEMBERG	RED STRAIGHT / ROSSO DRITTO	18 x 4 x 1.560	
8909	WOHLEMBERG	GREY STRAIGHT / GRIGIO DRITTO	18 x 4 x 1.560	
8910	WOHLEMBERG	RED STRAIGHT / ROSSO DRITTO	11 x 3 x 909	
8912	WOHLEMBERG	RED STRAIGHT / ROSSO DRITTO	11 x 3 x 1.157	
8914	WOHLEMBERG	RED STRAIGHT / ROSSO DRITTO	13 x 13 x 926	
8915	WOHLEMBERG	RED STRAIGHT / ROSSO DRITTO	13 x 13 x 1.157	
8916	WOHLEMBERG	RED STRAIGHT / ROSSO DRITTO	15 x 15 x 1.157	
8917	WOHLEMBERG	RED WAVY / ROSSO ONDULATO	10 x 4 x 770	
8918	WOHLEMBERG	RED WAVY / ROSSO ONDULATO	10 x 4 x 930	
8919	WOHLEMBERG	RED WAVY / ROSSO ONDULATO	10 x 4 x 1.190	
8920	WOHLEMBERG	GREY STRAIGHT / GRIGIO DRITTO	13 x 13 x 1.157	
8922	SCHNEIDER SENATOR	RED STRAIGHT / ROSSO DRITTO	12 x 3 x 821	
8924	SCHNEIDER SENATOR	RED STRAIGHT / ROSSO DRITTO	12 x 3 x 1.151	
8926	SCHNEIDER SENATOR	RED STRAIGHT / ROSSO DRITTO	12 x 3 x 1.551	
8930	SCHNEIDER SENATOR	RED STRAIGHT / ROSSO DRITTO	14 x 14 x 821	
8932	SCHNEIDER SENATOR	RED STRAIGHT / ROSSO DRITTO	14 x 14 x 1.061	
8934	SCHNEIDER SENATOR	RED STRAIGHT / ROSSO DRITTO	14 x 14 x 1.370	
8935	SCHNEIDER SENATOR	RED STRAIGHT / ROSSO DRITTO	14 x 14 x 1.600	
8942	MANDELLI LLM	RED STRAIGHT / ROSSO DRITTO	16 x 16 x 765	
8944	MANDELLI LLM	RED STRAIGHT / ROSSO DRITTO	16 x 16 x 930	
8946	MANDELLI LLM	RED STRAIGHT / ROSSO DRITTO	16 x 16 x 1.080	
8948	MANDELLI LLM	RED STRAIGHT / ROSSO DRITTO	16 x 16 x 1.335	
8950	MANDELLI LLM	RED STRAIGHT / ROSSO DRITTO	16 x 16 x 1.575	

Ref. Codice	Machine Macchina	Color & type Colore e tipo	Measure Misura	€
8951	HEROLD	RED STRAIGHT / ROSSO DRITTO	18 x 5 x 840	
8952	HEROLD	RED STRAIGHT / ROSSO DRITTO	18 x 5 x 930	
8953	HEROLD	RED STRAIGHT / ROSSO DRITTO	18 x 5 x 1.080	
8954	HEROLD	RED STRAIGHT / ROSSO DRITTO	18 x 5 x 1.160	
8955	THREELATERAL / TRILATERALE	RED or GREY / ROSSO o GRIGIO	24 x 4 x 1.200	
8956	THREELATERAL / TRILATERALE	RED or GREY / ROSSO o GRIGIO	41 x 4 x 1.200	
8957	THREELATERAL / TRILATERALE	RED or GREY / ROSSO o GRIGIO	60 x 4 x 1.200	
8958	THREELATERAL / TRILATERALE	RED or GREY / ROSSO o GRIGIO	11 x 4 x 1.200	
8959	THREELATERAL / TRILATERALE	RED or GREY / ROSSO o GRIGIO	13 x 4 x 1.200	
8962	PIVANO PERFECTA	RED STRAIGHT / ROSSO DRITTO	10 x 5 x 840	
8963	PIVANO PERFECTA	RED STRAIGHT / ROSSO DRITTO	10 x 5 x 1.138	
8964	PIVANO PERFECTA	RED STRAIGHT / ROSSO DRITTO	10 x 5 x 1.368	
8965	PIVANO PERFECTA	RED STRAIGHT / ROSSO DRITTO	10 x 5 x 1.715	
8968	PIVANO PERFECTA	RED STRAIGHT / ROSSO DRITTO	19 x 19 x 838	
8969	PIVANO PERFECTA	RED STRAIGHT / ROSSO DRITTO	19 x 19 x 1.073	
8970	PIVANO PERFECTA	RED STRAIGHT / ROSSO DRITTO	19 x 19 x 1.130	
8971	PIVANO PERFECTA	RED STRAIGHT / ROSSO DRITTO	12 x 4 x 1.070	
8976	SAROGLIA	RED STRAIGHT / ROSSO DRITTO	20 x 20 x 890	
8977	SAROGLIA	RED STRAIGHT / ROSSO DRITTO	20 x 20 x 1.065	
8978	SAROGLIA	RED STRAIGHT / ROSSO DRITTO	20 x 20 x 1.325	
8980	PIVANO SAROGLIA	RED STRAIGHT / ROSSO DRITTO	10 x 10 x 850	
8981	PIVANO SAROGLIA	RED STRAIGHT / ROSSO DRITTO	10 x 10 x 1.095	
8982	PIVANO SAROGLIA	RED STRAIGHT / ROSSO DRITTO	10 x 10 x 1.325	
8983	OMAC NEBIOLO	RED STRAIGHT / ROSSO DRITTO	9,5 x 5 x 1.505	
8984	OMAC NEBIOLO	RED STRAIGHT / ROSSO DRITTO	9,7 x 5 x 760	
8985	OMAC NEBIOLO	RED STRAIGHT / ROSSO DRITTO	9,7 x 5 x 840	
8986	OMAC NEBIOLO	RED STRAIGHT / ROSSO DRITTO	9,7 x 5 x 1.120	
8987	OMAC NEBIOLO	RED STRAIGHT / ROSSO DRITTO	9,7 x 5 x 1.230	
8988	OMAC NEBIOLO	RED STRAIGHT / ROSSO DRITTO	9,7 x 5 x 1.500	
8989	OMAC NEBIOLO	RED STRAIGHT / ROSSO DRITTO	15 x 15 x 760	
8990	OMAC NEBIOLO	RED STRAIGHT / ROSSO DRITTO	15 x 15 x 830	
8991	OMAC NEBIOLO	RED STRAIGHT / ROSSO DRITTO	15 x 15 x 930	
8992	OMAC NEBIOLO	RED STRAIGHT / ROSSO DRITTO	15 x 15 x 1.120	
8993	OMAC NEBIOLO	RED STRAIGHT / ROSSO DRITTO	15 x 15 x 1.320	
8994	OMAC NEBIOLO	RED STRAIGHT / ROSSO DRITTO	15 x 15 x 1.555	
8996	F.T.P.	RED STRAIGHT / ROSSO DRITTO	16 x 5 x 820	
8997	F.T.P.	RED STRAIGHT / ROSSO DRITTO	16 x 5 x 1.070	
8998	F.T.P.	RED STRAIGHT / ROSSO DRITTO	16 x 5 x 1.120	
8999	F.T.P.	RED STRAIGHT / ROSSO DRITTO	16 x 5 x 1.150	
8891	VICKING	RED STRAIGHT / ROSSO DRITTO	-	



PRE-PRESS

PRESTAMPA

Ref. Codice	Description Descrizione	Measure Misura	€
3400	BIG CUTTER CUTTER GRANDE	-	
3402	BIG KAI BLADES / LAMETTE GRANDI KAI	BOX 10 PCS - CONF 10 PZ.	
3404	SMALL CUTTER CUTTER PICCOLO	-	
3406	SMALL KAI BLADES / LAMETTE PICCOLE KAI	BOX 10 PCS - CONF 10 PZ.	
3410	SCISSORS / FORBICI	14 cm	
3416	SCISSORS / FORBICI	25 cm	
3350	NIBS FOR FILM - BOX 20 PCS SGARZINI PER PELLICOLA - CONF 20 PZ.		
3352	SMALL STAWS FOR NIBS CANNUCCIA PER SGARZINI	-	
6223	TYPOGRAPHIC TWEEZERS PINZETTA TIPOGRAFICA CON PUNTA	-	
4130	POLYSTIRENE TAB TAMPONE IN POLISTIROLO	-	
4134	PLASTIC and RUBBER DOCTOR BLADE RACLA IN PLASTICA e GOMMA	L: 40 cm	

MAGNIFIER

LENTINI

Ref. Codice	Description Descrizione	Measure Misura	€
3502	SMALL MAGNIFIER 20x20 - 8 MAGNIFICATIONS LENTINO 20x20 - 8 INGRANDIMENTI		
3506	SMALL MAGNIFIER 30x30 - 6 MAGNIFICATIONS LENTINO 30x30 - 6 INGRANDIMENTI		
3424	MAGNIFIER Ø50 mm WITH HANDLE LENTE Ø50 mm CON MANICO		
3428	MAGNIFIER Ø70 mm WITH HANDLE LENTE Ø70 mm CON MANICO		

MEASURING INSTRUMENTS

STRUMENTI DI MISURA

Ref. Codice	Description Descrizione	Measure Misura	€
6214	STEEL TYPOMETER TIPOMETRO IN ACCIAIO	36 cm	
6216	STEEL TYPOMETER TIPOMETRO IN ACCIAIO	50 cm	
6408	MICROMETER MICROMETRO		
6409	DECIMAL STOP BAR CASE SPESSIMETRO DECIMALE		
6410	SMALL SCALE FOR PAPER BILANCINA PESA CARTA		

WASHING**LAVAGGIO**

Ref. Codice	Description Descrizione	Measure Misura	€
4152	PRESSED SPONGES SPUGNE PRESSATE	14 x 10 cm	
4154	CELLULOSE SPONGES SPUGNE IN CELLULOSA	14 x 10 cm	
4158	MEDIUM SIZE MARINE SPONGES SPUGNE MARINE MEDIE	-	
3040	TEX CLOTH ROLL BOBINA PANNI TEX	5 Kg	
6414	PLASTIC BOTTLE WITH STRAW BOCCHETTA PLASTICA CON CANNUCCIA	1 l	
3604	ANTI-ACID GLOVES GUANTI ANTIACIDO	8	
3606	ANTI-ACID GLOVES GUANTI ANTIACIDO	9	
3608	ANTI-ACID GLOVES GUANTI ANTIACIDO	10	
3610	LATEX GLOVES GUANTI IN LATTICE	SMALL (box 100 pcs)	
3611	LATEX GLOVES GUANTI IN LATTICE	MEDIUM (box 100 pcs)	
3612	LATEX GLOVES GUANTI IN LATTICE	LARGE (box 100 pcs)	

INK KNIVES**SPATOLE PER INCHIOSTRO**

Ref. Codice	Description Descrizione	Measure Misura	€
6230	METAL INK KNIFE SPATOLA IN ACCIAIO	3 cm	
6231	METAL INK KNIFE SPATOLA IN ACCIAIO	4 cm	
6232	METAL INK KNIFE SPATOLA IN ACCIAIO	5 cm	
6233	METAL INK KNIFE SPATOLA IN ACCIAIO	6 cm	
6234	METAL INK KNIFE SPATOLA IN ACCIAIO	7 cm	
6235	METAL INK KNIFE SPATOLA IN ACCIAIO	8 cm	
6236	METAL INK KNIFE SPATOLA IN ACCIAIO	9 cm	
6237	METAL INK KNIFE SPATOLA IN ACCIAIO	10 cm	
6240	PLASTIC INK KNIVES - KIT 4 KNIVES BLACK+RED+YELLOW+CYAN SPATOLE IN PLASTICA - KIT 4 SPATOLE NERA+ROSSA+GIALLA+CIANO	4,5 cm	
6241	PLASTIC INK KNIVES - KIT 4 KNIVES BLACK+RED+YELLOW+CYAN SPATOLE IN PLASTICA - KIT 4 SPATOLE NERA+ROSSA+GIALLA+CIANO	7 cm	

PLASTIC FEEDER WEDGES**CUNEI IN PLASTICA**

Ref. Codice	Description Descrizione	Measure Misura	€
9496	FEEDER WEDGE "A" CUNEO "A"	30 x 35 x 105 mm	
9497	FEEDER WEDGE "B" CUNEO "B"	30 x 35 x 195 mm	
9498	FEEDER WEDGE "C" CUNEO "C"	30 x 60 x 195 mm	
9499	FEEDER WEDGE "D" CUNEO "D"	25 x 75 x 195 mm	

BI-ADHESIVE**BIADESIVO**

Ref. Codice	Type Tipo	Color Colore	Size Misura	€
6591	SCAPA TAPE 010 - PVC	BROWN / MARRONE	310 mm x 4,5 m	
6592	SCAPA TAPE 020 - PVC	WHITE / BIANCO	310 mm x 4,5 m	
6593	SCAPA TAPE 030 - PVC	GREEN / VERDE	310 mm x 4,5 m	
2310	TESA 010 - PVC	WHITE / BIANCO	310 mm x 10 m	
2320	TESA 020 - PVC	WHITE / BIANCO	310 mm x 10 m	
2330	TESA 030 - TELATO	WHITE / BIANCO	310 mm x 4,5 m	
6594	BI-ADHESIVE "TRANSFER"	BOX 12	12 mm x 33 m	
6595	BI-ADHESIVE "TRANSFER"	BOX 8	19 mm x 33 m	
6596	DISPENSER FOR BI-ADHESIVE "TRANSFER" ATS-50 DISPENSER PER BIADESIVO "TRANSFER" ATS-50			

PACKAGING**IMBALLO**

Ref. Codice	Description Descrizione	Measure Misura	€
6640	CARTON SEALING TAPE ROTOLO PVC AVANA PER IMBALLO	50 m x 66 mm	
6641	HAND DISPENSER DISPENSER NASTRO ADESIVO	-	
6597	STRETCH-FILM 500 mm x 23 my - int. Ø 50 mm - 2,7 Kg FILM ESTENSIBILE	BOX 6 ROLLS	
6598	DISPENSER FOR STRETCH-FILM DISPENSER FILM ESTENSIBILE	-	

OTHER**ARTICOLI VARI**

Ref. Codice	Description Descrizione	Measure Misura	€
6424	SILICONE-BASED SLIDING SPRAY SCIVOLANTE SPRAY AL SILICONE	400 ml	
8087	BONE FOLDER PIGHETTA OSSO	L: 16 cm	

CONDIZIONI GENERALI DI VENDITA

1 - APPLICAZIONE DELLE CONDIZIONI

Le presenti Condizioni Generali di Vendita regolano tutti i rapporti tra Fedrigo Forniture Grafiche S.r.l. (di seguito "Fedrigo") ed il Cliente se non espressamente derogate da condizioni particolari confermate per iscritto dalla stessa Fedrigo.

2 - ORDINI

Tutti gli ordini vanno emessi per lettera, per telefax o per e-mail. La Fedrigo si riserva la facoltà di accettare ordini telefonici e verbali. Ogni clausola o condizione particolare di acquisto figurante sull'ordine del Cliente e che sia in contraddizione con le Condizioni Generali di Vendita in vigore in quell'anno sarà considerata nulla. Le ordinazioni devono rispettare i confezionamenti riportati sul listino prezzi e non potranno essere inferiori a 100,00 € netti.

3 - CONSEGNA E SPEDIZIONE

Salvo pattuizione contraria, tutte le vendite della Fedrigo si intendono effettuate con spedizione e consegna in porto franco con addebito in fattura e SENZA alcuna assicurazione. Pertanto la scelta dello spedizioniere sarà fatta esclusivamente dalla Fedrigo. Quest'ultima compirà ogni ragionevole sforzo per rispettare i tempi di spedizione e di consegna come concordati, secondo le richieste del Cliente.

La merce viaggia sempre a rischio e pericolo del committente il quale, nel proprio interesse, deve verificare, prima del ritiro, l'integrità dei colli e la quantità della merce ricevuta. La responsabilità della Fedrigo cessa nel momento in cui le merci vengono consegnate al vettore contro il quale il committente dovrà avanzare ogni eventuale reclamo al momento della consegna.

4 - TERMINI DI CONSEGNA

La merce si intende resa franco nostro stabilimento di Brescia. I termini di consegna previsti dalla Fedrigo sono indicativi e non essenziali e la Fedrigo non potrà pertanto essere considerata responsabile per danni o qualsiasi penalità derivante da una ritardata consegna. La Fedrigo si riserva il diritto di effettuare consegne parziali con conseguente emissione di fatture da pagarsi nei termini concordati nella conferma d'ordine.

5 - PREZZI

Tutti i prezzi indicati sono espressi in Euro e vanno intesi IVA ESCLUSA. Fedrigo si riserva la facoltà insindacabile di apportare variazioni ai prezzi di listino pubblicati nel caso in cui le componenti di costo dei singoli articoli lo rendessero necessario. Sugli importi delle fatture non si accettano né decurtazioni né arrotondamenti.

6 - RESI

Eventuali contestazioni devono essere inviate per iscritto alla Fedrigo entro 8 giorni dal ricevimento della merce. La restituzione della merce dovrà essere preventivamente autorizzata dalla Fedrigo. I resi autorizzati dovranno essere inviati ai magazzini della Fedrigo Forniture Grafiche in porto franco, corredati di regolare bolla d'accompagnamento e dei relativi estremi d'acquisto. La merce verrà accreditata al prezzo di acquisto decurtato del 15% per oneri amministrativi e di collaudo. In nessun caso saranno accettati resi trascorsi 6 mesi dalla data di acquisto.

7 - MISURE E DISEGNI

Le indicazioni di misure e disegni su qualsiasi pubblicazione Fedrigo sono da intendersi a puro titolo informativo e possono essere soggette a modifiche senza alcun preavviso.

8 - PAGAMENTI

Tutte le fatture debbono essere pagate alla Sede della Fedrigo in Flero (BS) entro i termini pattuiti. Per Clienti che emettono per la prima volta ordini alla Fedrigo, il pagamento potrà essere effettuato per contanti al ritiro della merce. Eventuali contestazioni relative alle fatture devono pervenire mediante lettera raccomandata A/R alla Fedrigo entro 8 gg. dalla data di ricezione delle stesse, diversamente non saranno prese in considerazione e le fatture stesse si intenderanno accettate senza alcuna riserva. Eventuali ritardi nei pagamenti comporteranno l'addebito degli interessi moratori al tasso legale aumentato di 3 (tre) punti e la sospensione delle forniture. Non sono consentiti sconti se non autorizzati dalla Fedrigo. Il Cliente non è autorizzato ad effettuare alcuna deduzione dal prezzo stabilito (ad es. pagamento anticipato, o in caso di pretesi difetti dei Prodotti), se non previo accordo scritto con Fedrigo. Qualora la Fedrigo avesse motivo di temere che il Cliente non potesse o non intendesse pagare i Prodotti alla data pattuita, Fedrigo potrà subordinare la consegna dei prodotti alla prestazione di adeguate garanzie di pagamento.

9 - PROPRIETÀ DELLA MERCE

Fedrigo Forniture Grafiche S.r.l. resta proprietaria della merce fino al completo pagamento della stessa da parte del cliente.

10 - FORO COMPETENTE

Per qualsiasi ed eventuale controversia si intende competente il Foro di Brescia.

GENERAL CONDITIONS OF SALES

1 - FORMATION OF SALES CONTRACT

Any order implies strict adherence by the purchaser to these General Conditions of Sales. These conditions will prevail over any customer's writing or general condition of purchase except in the cases of concessions previously accepted by Fedrigo Forniture Grafiche (Fedrigo) of which the customer has been notified in writing.

2 - ORDERS

We only accept orders sent by normal post, telefax or e-mail. Fedrigo reserve to accept telephonic or verbal orders. No variation to these conditions shall be binding unless agreed in writing between the authorised representatives of the purchaser and Fedrigo. Minimum order value is 100,00 €.

3 - DISPATCH

The goods are sold ex-works-Fedrigo Warehouses in Flero (BS). Consequently, the transfer of risks to the purchaser becomes effective on delivery of the goods to the carrier. The transport contract is made by Fedrigo on behalf of the purchaser and unless specified otherwise, goods are despatched using the most economical means available. No exception may be made to this rule, unless expressly agreed upon by Fedrigo and the purchaser. It is therefore the responsibility of the purchaser or consignee to take any action against the transporters and the insurers from the moment they receive the goods under the above conditions.

4 - DELIVERY DATES

Delivery dates quoted on order acknowledgements are given as an indication only and are in no way a firm commitment on the part of Fedrigo to deliver by a certain date. Consequently, no recourse, particularly when an order is cancelled or delivered late, may be brought against Fedrigo and damages may under no circumstances be claimed due to disputes arising between the purchaser and its customers. Moreover, Fedrigo reserve the right to deliver only a part of the goods ordered if forced to do so by events beyond its control.

5 - PRICES

Prices are in EUROS and without VAT. Except when specifically agreed by Fedrigo and the purchaser, prices exclude, unless stipulated otherwise, all types of expenses and costs, such as packaging costs, transport and insurance costs, customs duties, taxes and fiscal and fiscal-related charges (i.e. VAT).

6 - RETURN

Shortages in delivery or faults should be notified to Fedrigo within 8 day from date of delivery. Return are not accepted unless agreed in writing prior to return. Goods must be returned, in any case, free our work in Flero (BS) - Italy. Under no circumstances will goods be accepted for return that are older than 6 months.

7 - DESCRIPTION AND SPECIFICATION

Descriptions in catalogues, price lists and publicity brochures only represent the general nature of the products described. Fedrigo reserve the right to modify the model of all products without prior notice.

8 - PAYMENT

Except when stipulated otherwise, all invoices are payable net without discount to our Bank in Italy, within the deadline agreed. Any complaints concerning a supply do not entitle the purchaser to withhold any payment when due. Late payment, whether recovered by usual or judiciary means, is liable, without recourse to law, to be charged interest equal to one and a half times the current interest rate. Default of payment within the agreed terms and time authorises Fedrigo to stop further deliveries and cancel all or part of the order(s).

9 - PROPERTY RESERVE CLAUSE

Fedrigo Forniture Grafiche Srl reserve the property of goods delivered to their customers until complete payment of the whole price and its accessories.

10 - LEGAL DISPUTES

Any legal disputes in any form arising from the interpretation of or action according to these general conditions of sale, and/or any order, even in the case of incidental request or involving several parties, shall fall within the competence of the courts of Brescia (Italy).

CONTENTS**INDICE**

WASH-UP BLADES	2	LAME LAVARULLI
HICKEY REMOVERS	19	RACCOGLI GRUMI
CYLINDER JACKETS	20	CAMICIE CILINDRO STAMPA
ANTI MARKING SYSTEMS	23	RIVESTIMENTI "ANTI-MARKING"
PUNCHING PLATES	24	PIASTRE PER FUSTELLARE
INK FOUNTAIN BLADES	26	LAME DEL CALAMAIO
INK DUCT END BLOCKS	27	SPALLE DEL CALAMAIO
INK DUCT FOILS	29	COPRICALAMAI
mitsubishi CYLINDER WASHING BARS	29	BARRE LAVACILINDRO MITSUBISHI
PARTS FOR HEIDELBERG GTO	30	RICAMBI PER HEIDELBERG GTO
PARTS FOR HEIDELBERG PLATEN	32	RICAMBI PER STELLA HEIDELBERG
PARTS FOR TYPOGRAPHIC	33	RICAMBI PER MACCHINE TIPOGRAFICHE
SHEET SEPARATORS	34	SEPARAFOGLI
PARTS FOR FEEDER	36	RICAMBI PER METTIFOGLIO
OTHER SPARE PARTS	37	ALTRI RICAMBI
PIN BARS	38	BARRETTE DI MONTAGGIO
PUNCHES AND BENDERS	39	PUNZONATRICI E PIEGALASTRE
SHAPED SUCKERS	42	VENTOSE SAGOMATE
FLAT SUCKERS	48	VENTOSE PIATTE
QUOINS	49	SERRAFORME
JOGGER BLOCKS	49	SPINGI-CARTA
CREASING MATRIX	50	CANALETTI CORDONATORI
CREASING AND CUTTING RULES	52	FILETTI
OFFSET RULES	52	NASTRI PERFORATORI OFFSET
BELTS	53	CINGHIE
STEEL STAPLES	54	PUNTI METALLICI
STITCHING WIRES	54	FILO METALLICO
SMALL PUNCHES	55	FUSTELLINE
METALLIC EYELETS	55	OCCHIELLI METALLICI
TERMOGRAPHIC POWDER	55	POLVERE PER RILIEVO
GLUE	55	COLLE
PAPER DRILL BITS	56	PUNTE PER TRAPANI
CUTTING STICKS	58	LISTELLI SOTTOLAMA
PRE-PRESS	60	PRESTAMPA
MAGNIFIERS	60	LENTINI
MEASURING INSTRUMENTS	60	STRUMENTI DI MISURA
WASHING	61	LAVAGGIO
INK KNIVES	61	SPATOLE PER INCHIOSTRO
PLASTIC FEEDER WEDGES	61	CUNEI IN PLASTICA
BI-ADHESIVE	62	BIADESIVO
PACKAGING	62	IMBALLO
OTHERS	62	ARTICOLI VARI
CONDITIONS OF SALES	63	CONDIZIONI DI VENDITA